

72824

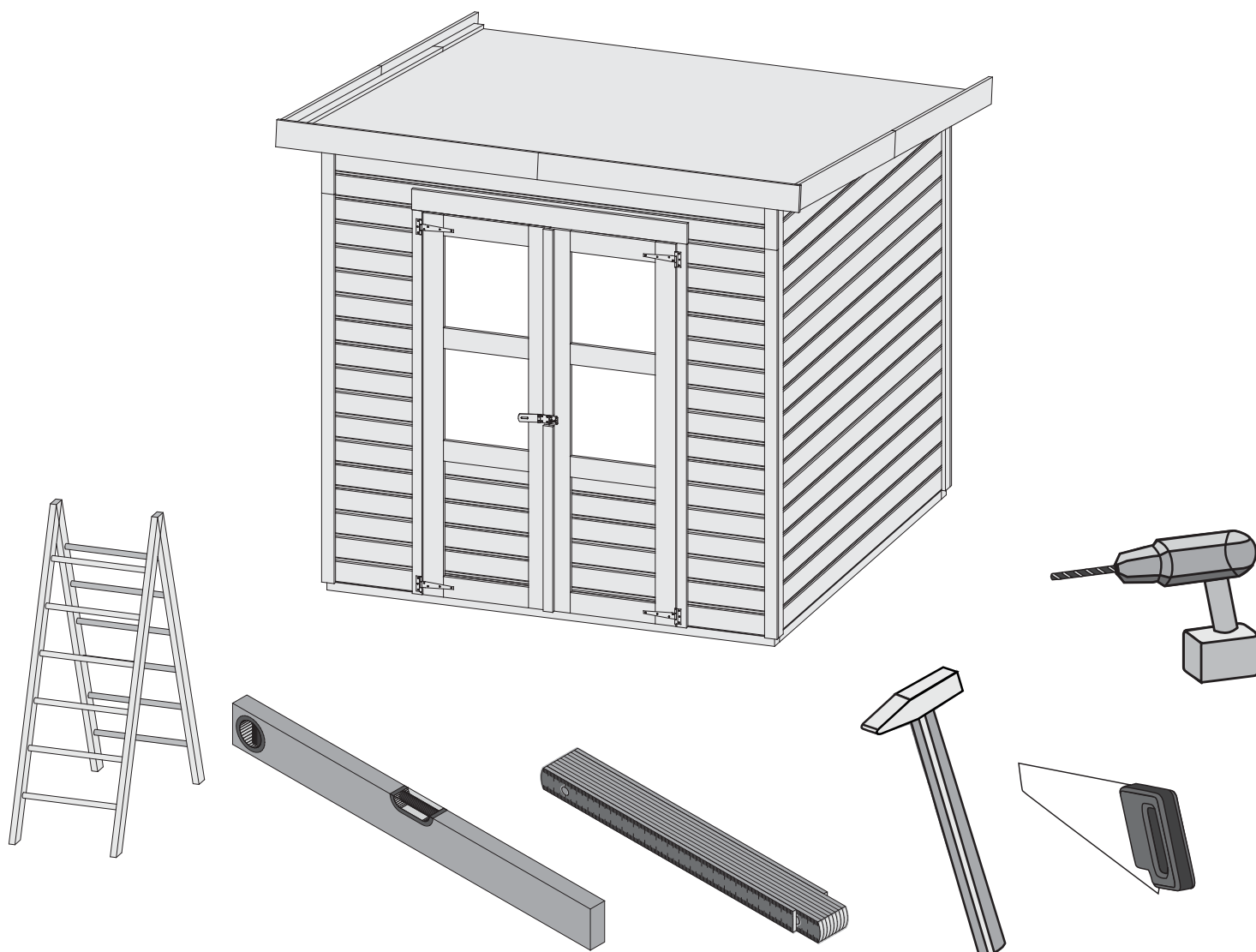

 **Aufbauanleitung**

 **notice de montage**

 **Building Instructions**

 **montagehandleiding**

 **Instrucciones de construcción**

 **Istruzioni per il montaggio**

 **Montážní návod**

 **Service-Hotline: +49 421 38693 33**



Vergleichen Sie zuerst die Materialliste mit Ihrem Paketinhalt! Bitte haben Sie Verständnis, dass Beanstandungen nur im nicht aufgebauten Zustand bearbeitet werden können!



En primer lugar, compare la lista de material con el contenido del paquete. Rogamos entienda que las reclamaciones sólo pueden ser tramitadas antes de montar el objeto!



Nejprve přezkontrolujte obsah balení podle materiálového listu! Mějte pochopení pro to, že případnou reklamaci se můžeme zabývat pouze tehdy, když díly nebudou smontované! Za pomoci tohoto seznamu můžete jednotlivé díly přiřadit k montážnímu návodu.



Vergelijk eerst de lijst van materialen met de inhoud van uw pakket! Reclamaties kunnen alleen in behandeling worden genomen zolang de onderdelen nog niet zijn gemonteerd!



First compare the list of materials with your package contents! Please understand that complaints can be processed in the non-built status only!



Commencez par comparer la liste du matériel avec le contenu de votre paquet! Sachez que nous traitons uniquement les réclamations concernant le matériel à l'état non monté!



Confrontate questa distinta materiali prima con il contenuto del pacchetto! Vi preghiamo di comprendere che eventuali reclami possono essere accolti solo prima del montaggio!

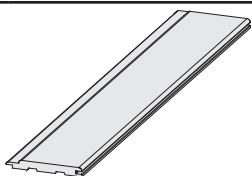
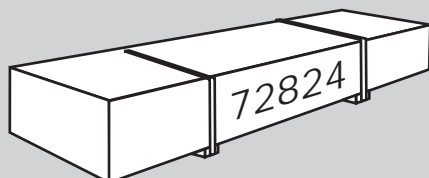

32 x U1	448 x 121 x 14mm	ID 61048
52 x U2	2080 x 121 x 14mm	ID 61034

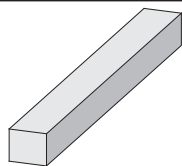

10 x B1	100 x 45 x 18mm	ID 19114
2 x B2	1748 x 45 x 18mm	ID 19208
1 x B3	1765 x 45 x 18mm	ID 16323
2 x B4	1768 x 45 x 18mm	ID 62952
7 x B5	1800 x 45 x 18mm	ID 19546
4 x B6	1980 x 58 x 18mm	ID 38947
4 x B7	2100 x 58 x 18mm	ID 28029
2 x B8	1280 x 95 x 18mm	ID 16404
2 x B9	2100 x 95 x 18mm	ID 11427
4 x B10	1200 x 120 x 18mm	ID 46499
2 x B11	1215 x 120 x 18mm	ID 25555
3 x B12	2053 x 95 x 36mm	ID 56261
5 x B13	1950 x 45 x 38mm	ID 41511
2 x B14	2050 x 45 x 38mm	ID 61049
2 x B15	1990 x 60 x 40mm	ID 15501
2 x B16	2080 x 60 x 40mm	ID 61047

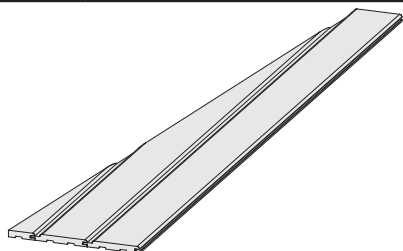

1 x P1	2080 x 279 x 14mm	ID 61064
1 x P2	2080 x 279 x 14mm	ID 61065

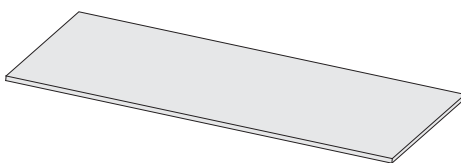

2 x N1	750 x 610 x 16mm	ID 58036
1 x N2	870 x 610 x 16mm	ID 58037
2 x N3	1740 x 750 x 16mm	ID 24227
1 x N4	1740 x 870 x 16mm	ID 45414

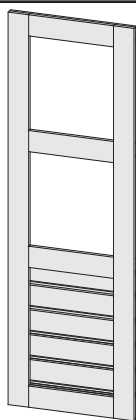

2 x D1	1760 x 585 x 14mm	ID 69356
--------	-------------------	----------

1 x



ID 16034

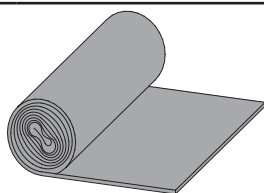

1 x

10m²

ID 16034



8 x	4 x 16mm	ID 3690
360 x	4 x 30mm	ID 3686
450 x	4 x 50mm	ID 3688
32 x	4,5 x 80mm	ID 9204

350 x



ID 3948

1 x

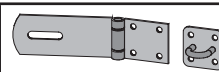

ID 3724

4 x

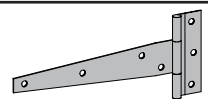

ID 3716

2 x

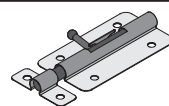

ID 3709



Pegamento
Colle
Glue
Lepek

1 x

ID 55202

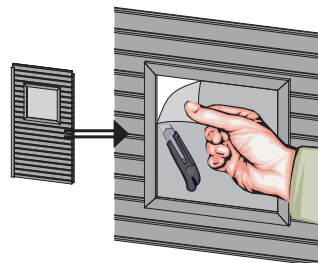

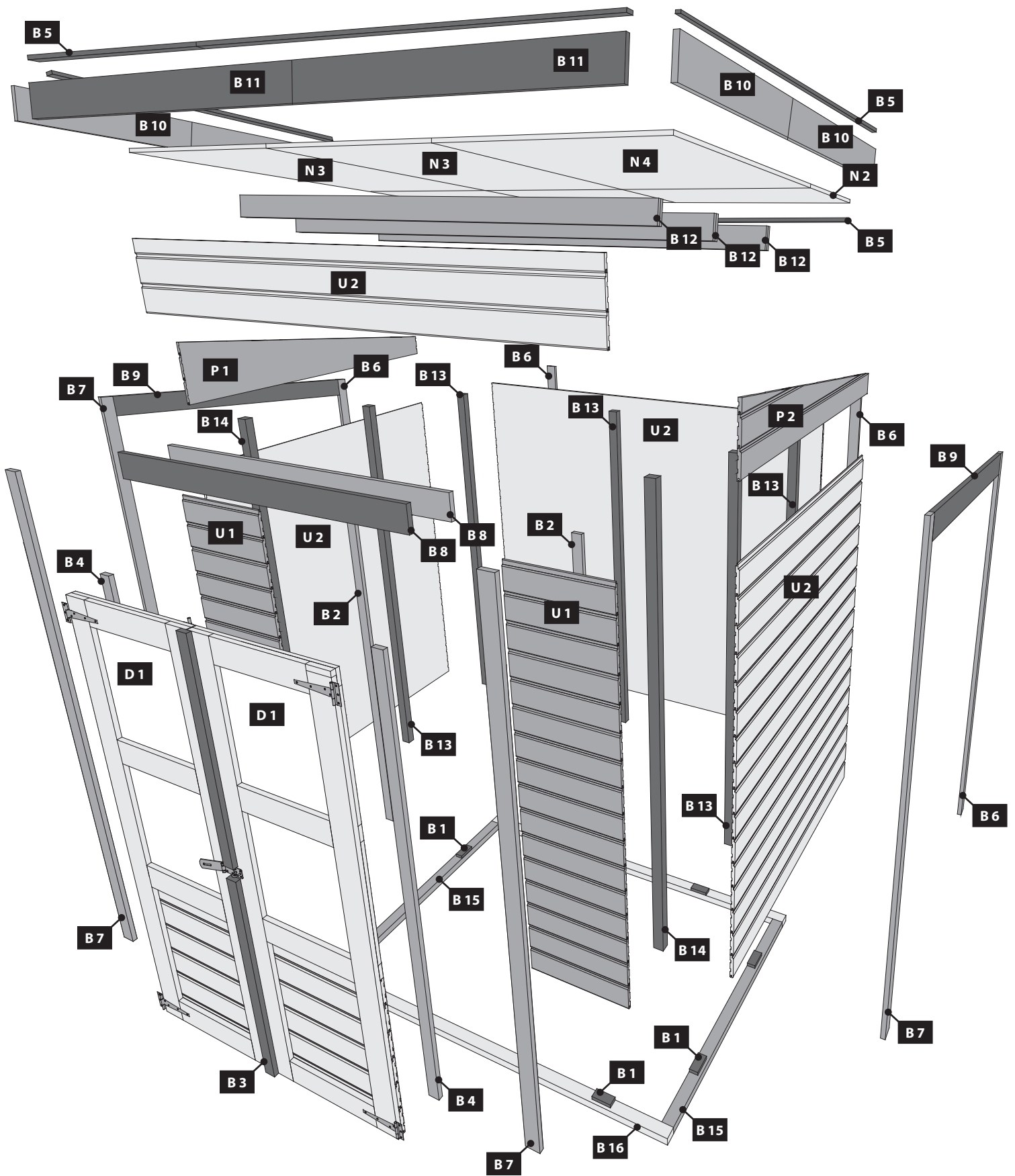

01

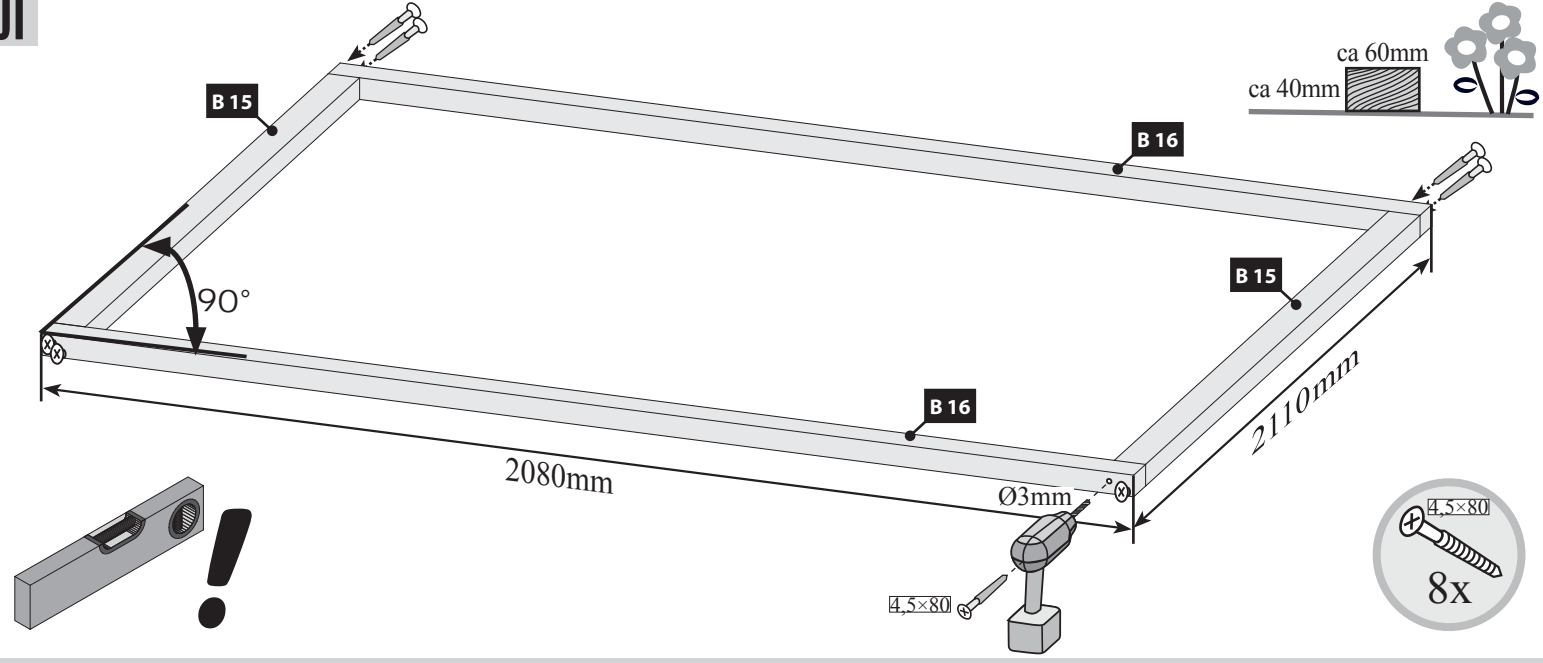

02

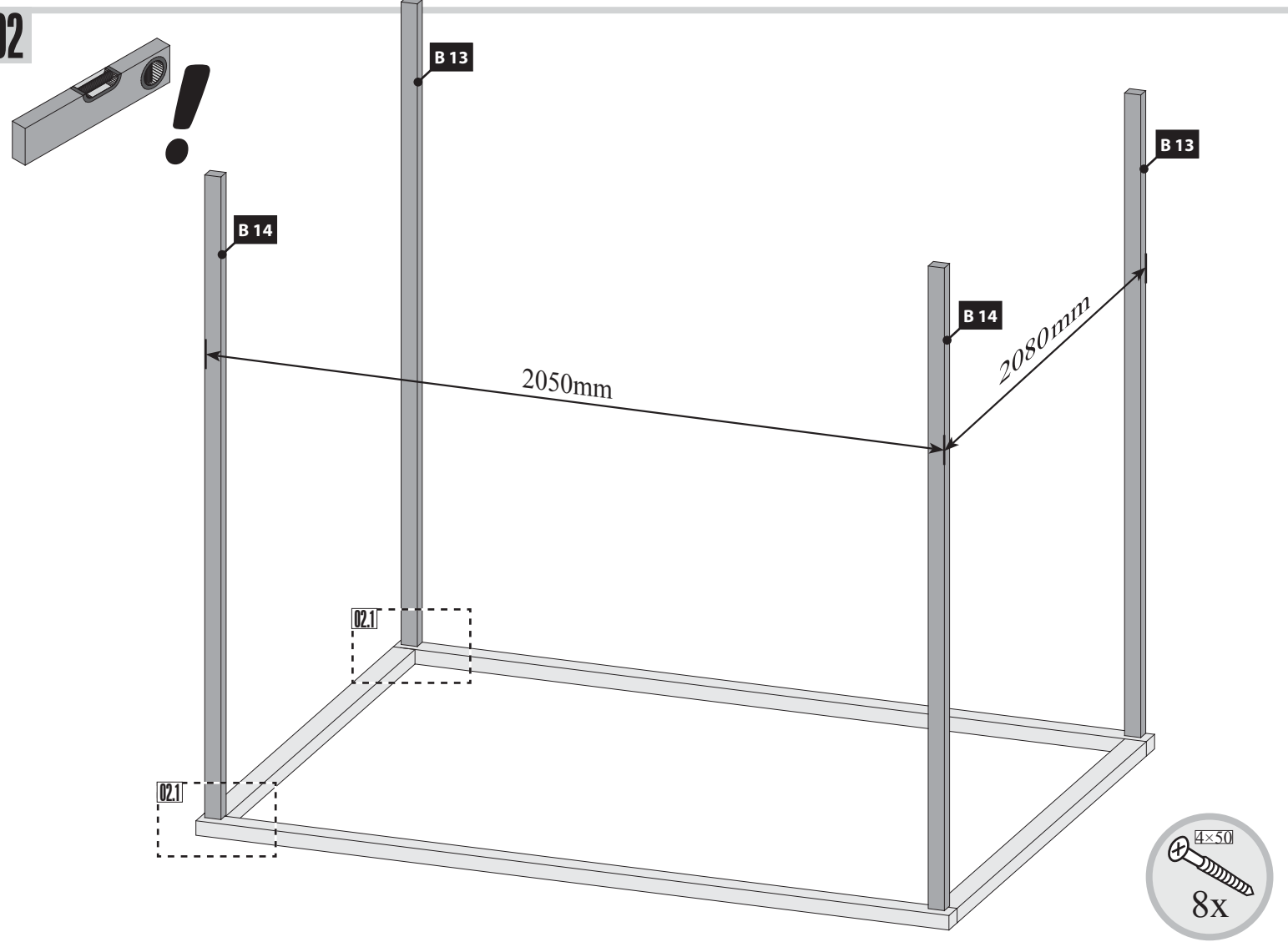

02.1

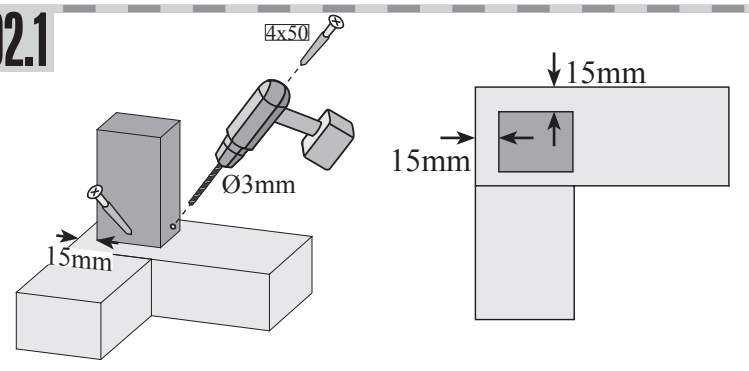

02.2

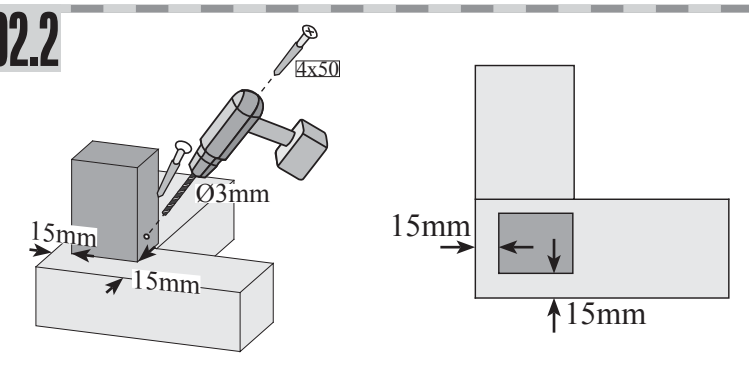

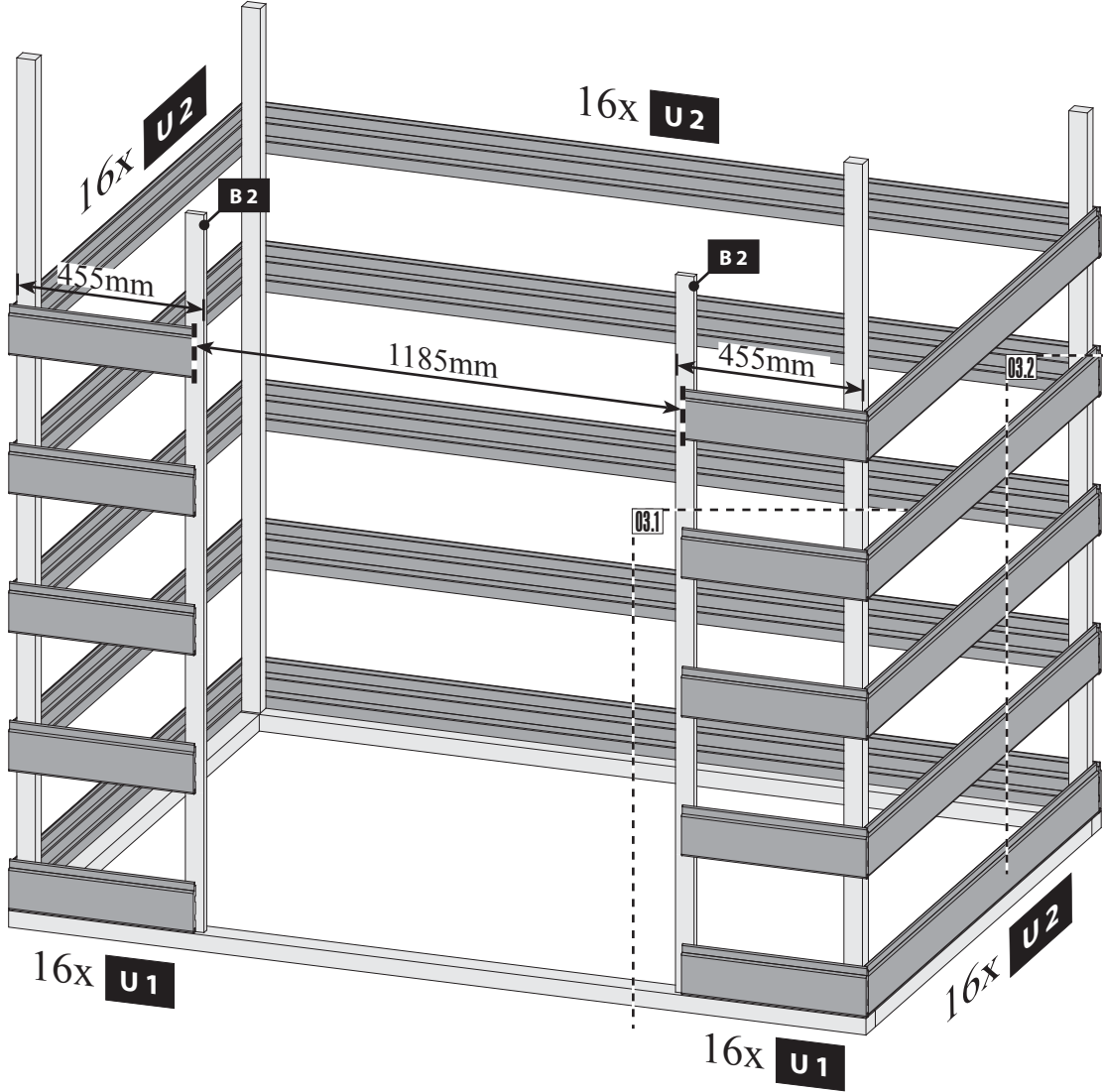

- Leim
- Colle
- Glue
- Lijm
- Pegamento
- Colla
- Klín

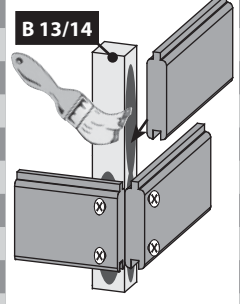

Bündig!
Affleurement!
Gelijk!
Aras!
Flush!
Combacia!
Flush!

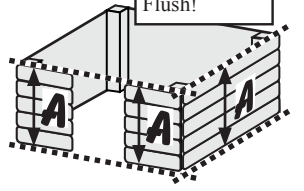

03.1

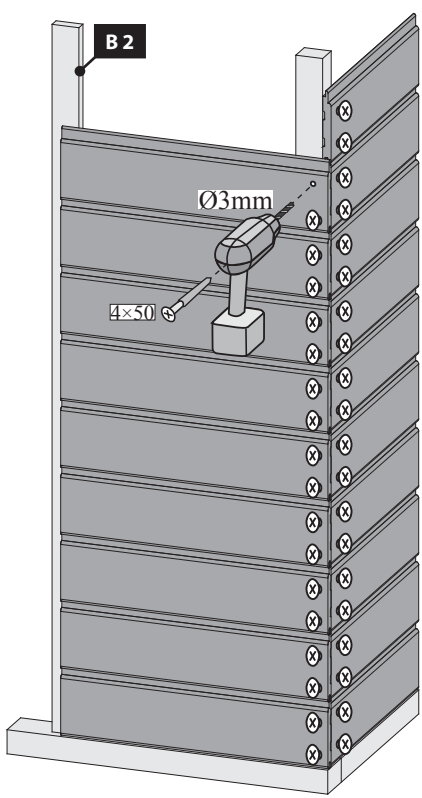
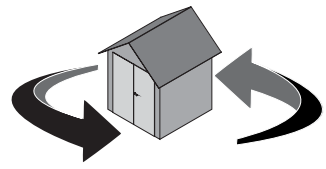
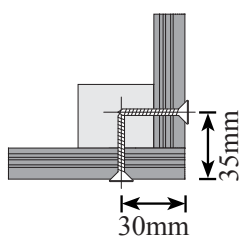

03.2

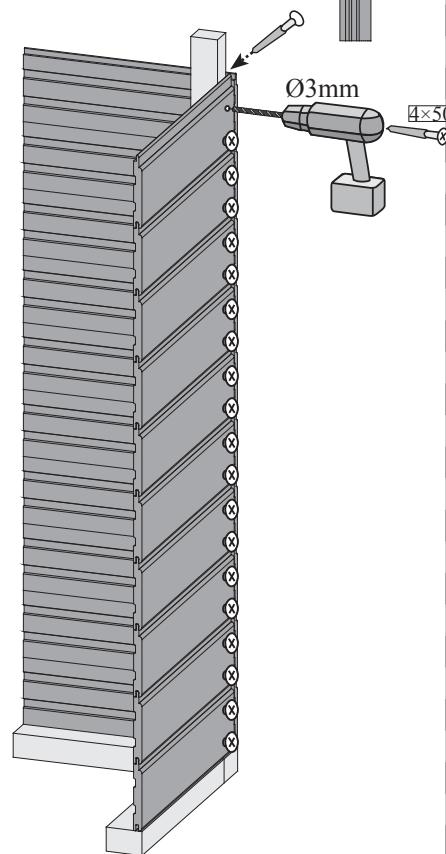
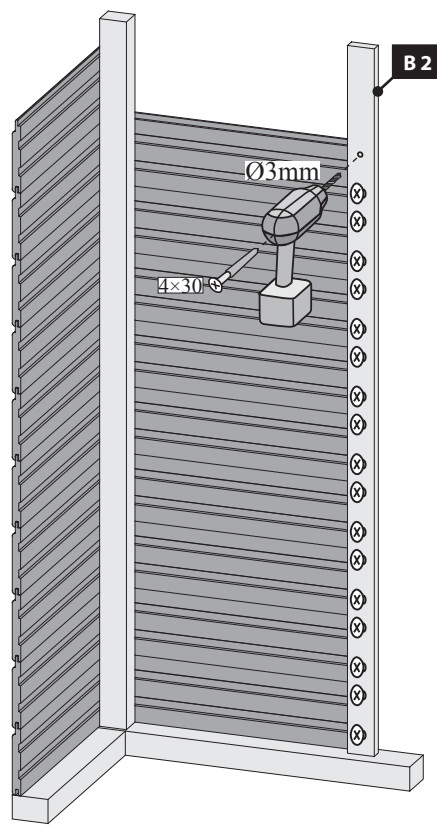
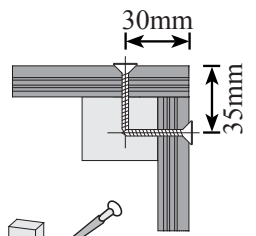

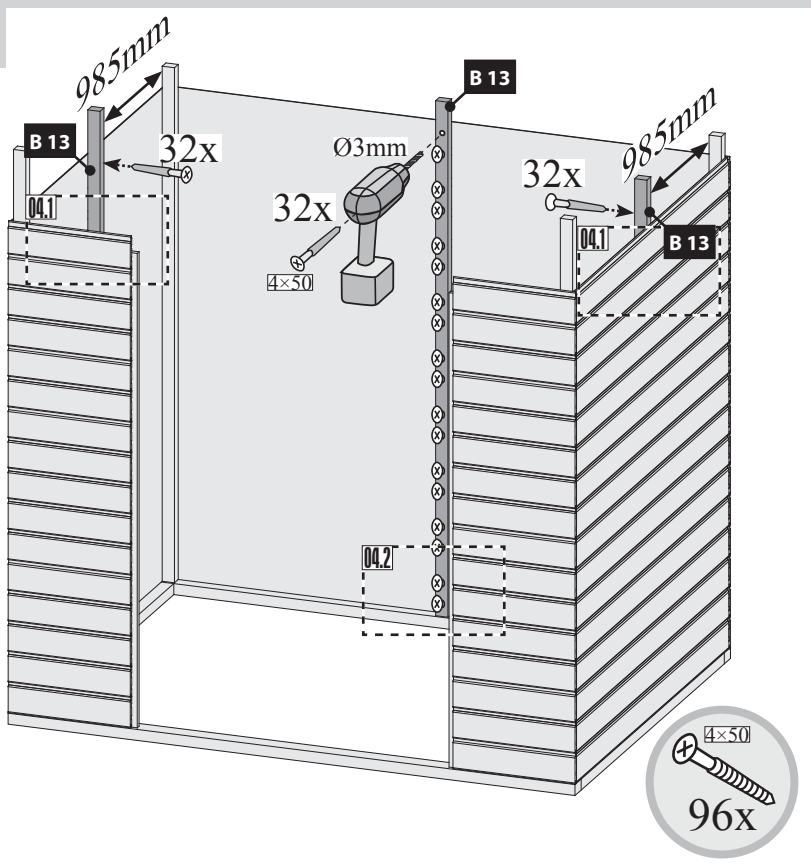
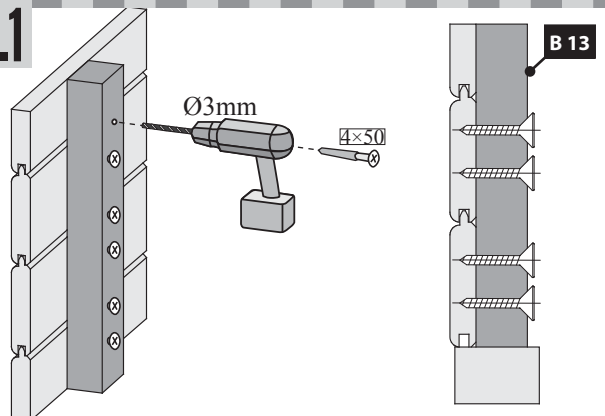
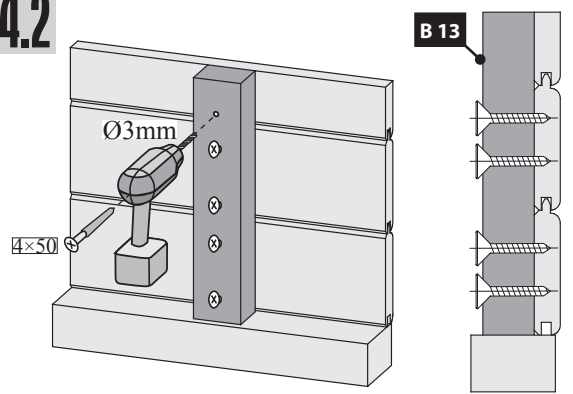
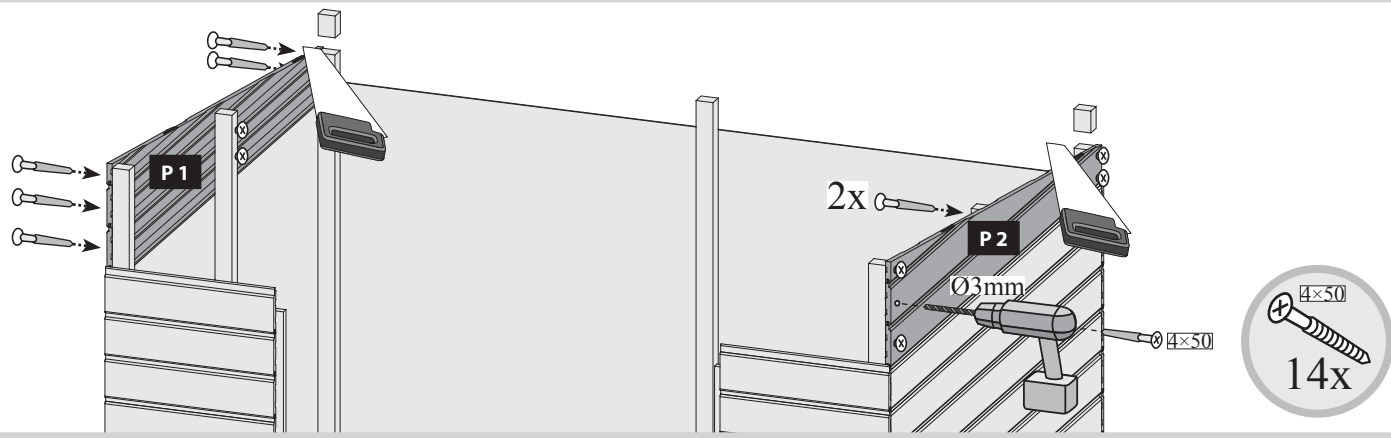
04**04.1****04.2****05****06**

Bündig!
Affleurement!
Gelijk!
Aras!
Flush!
Combacia!
Flush!

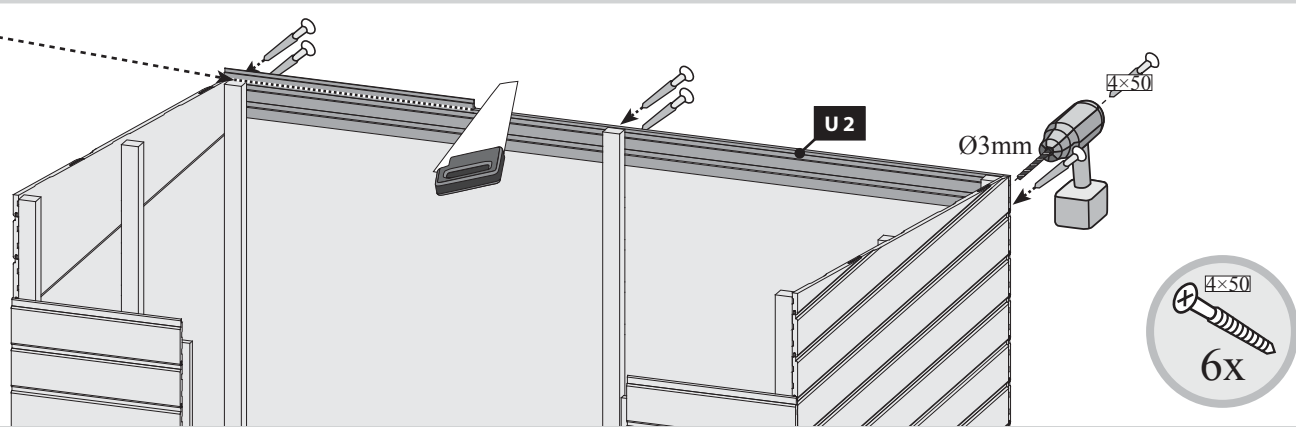
**07**

Bündig!
Affleurement!
Gelijk!
Aras!
Flush!
Combacia!
Flush!

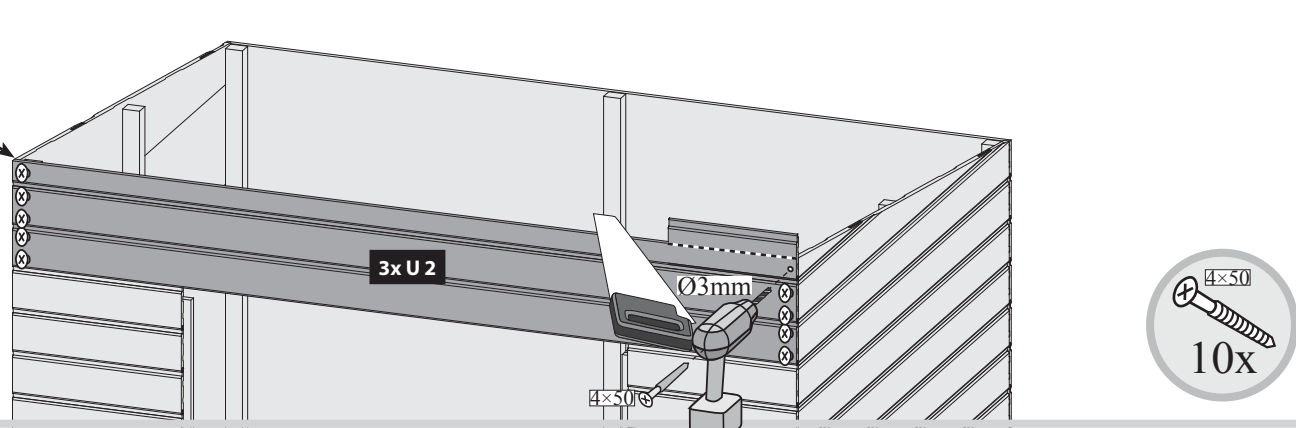

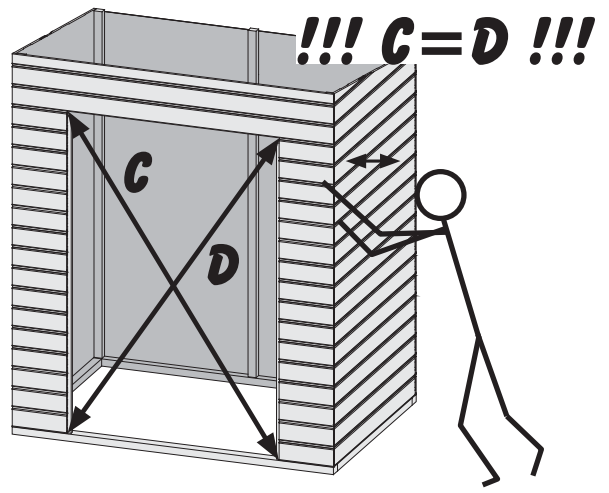
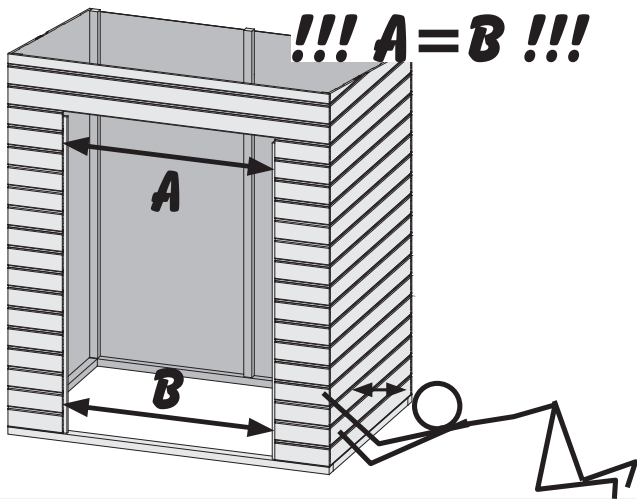

08

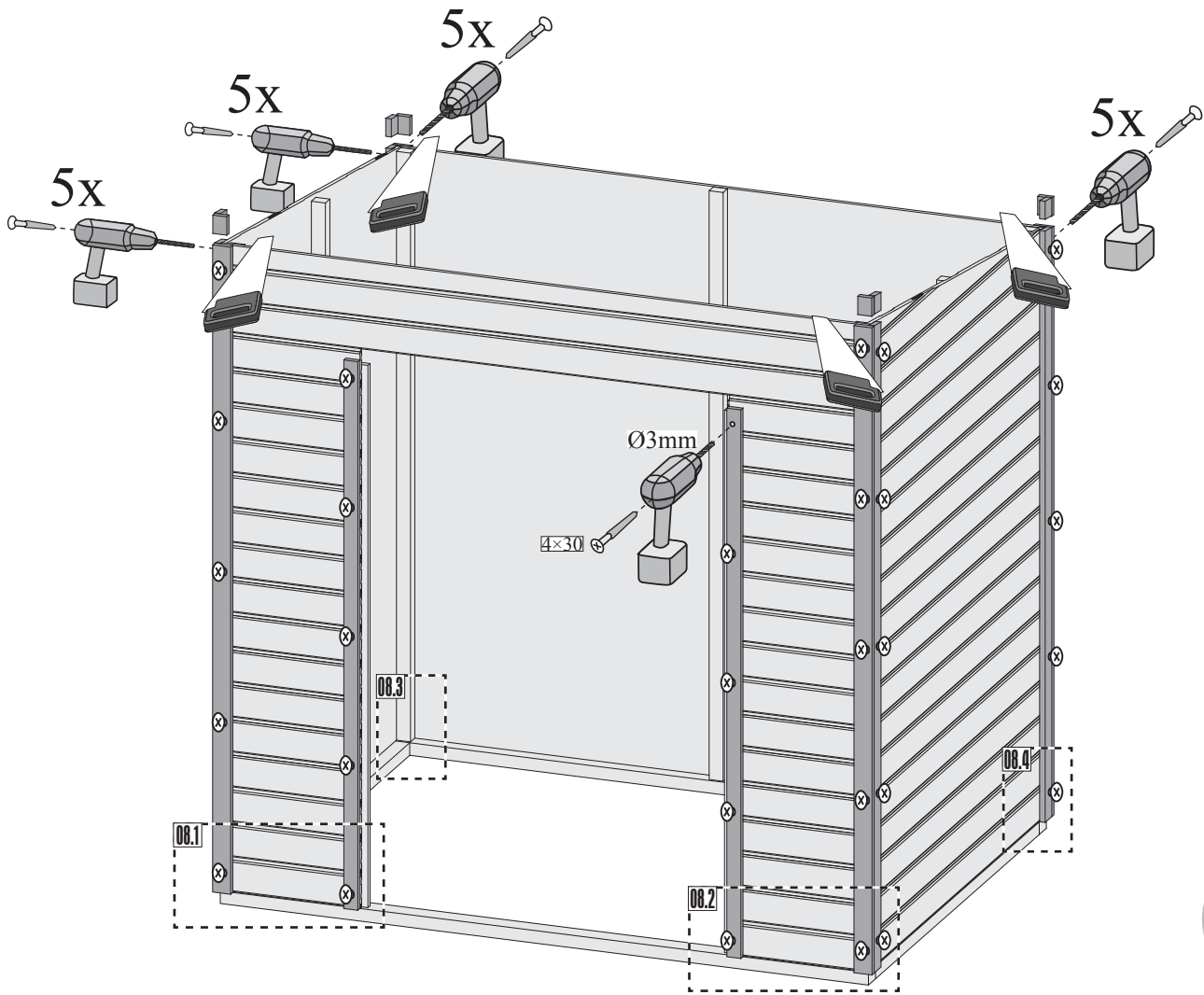

08.1

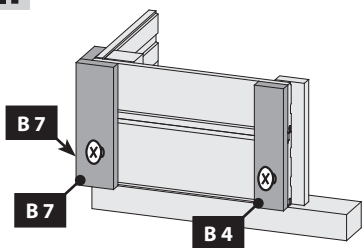

08.2

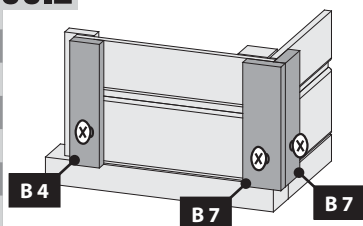

08.3

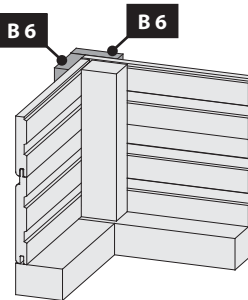

08.4

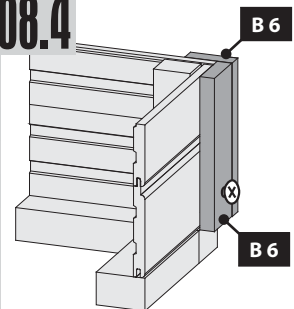

09

1x

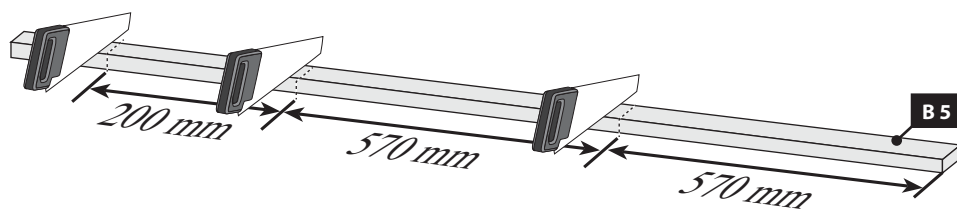

10

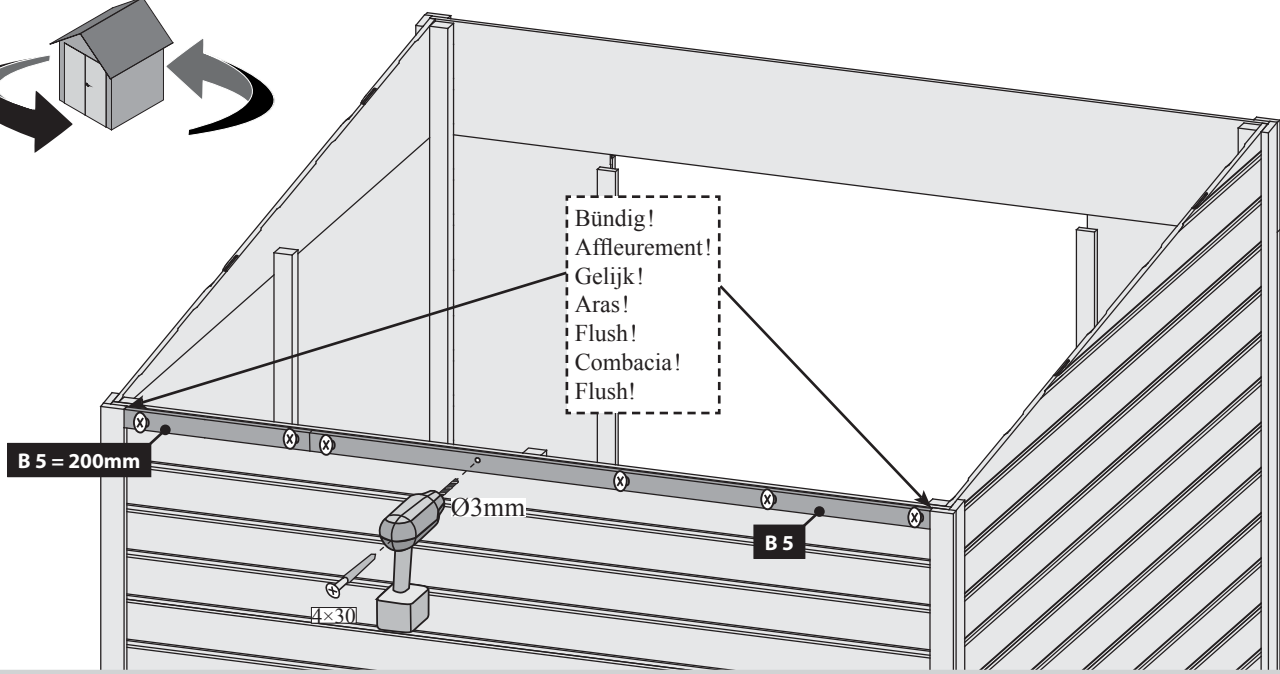
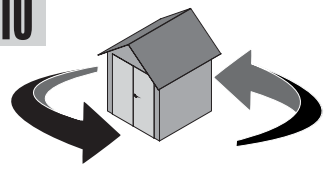

11

!!! A=B=C !!!

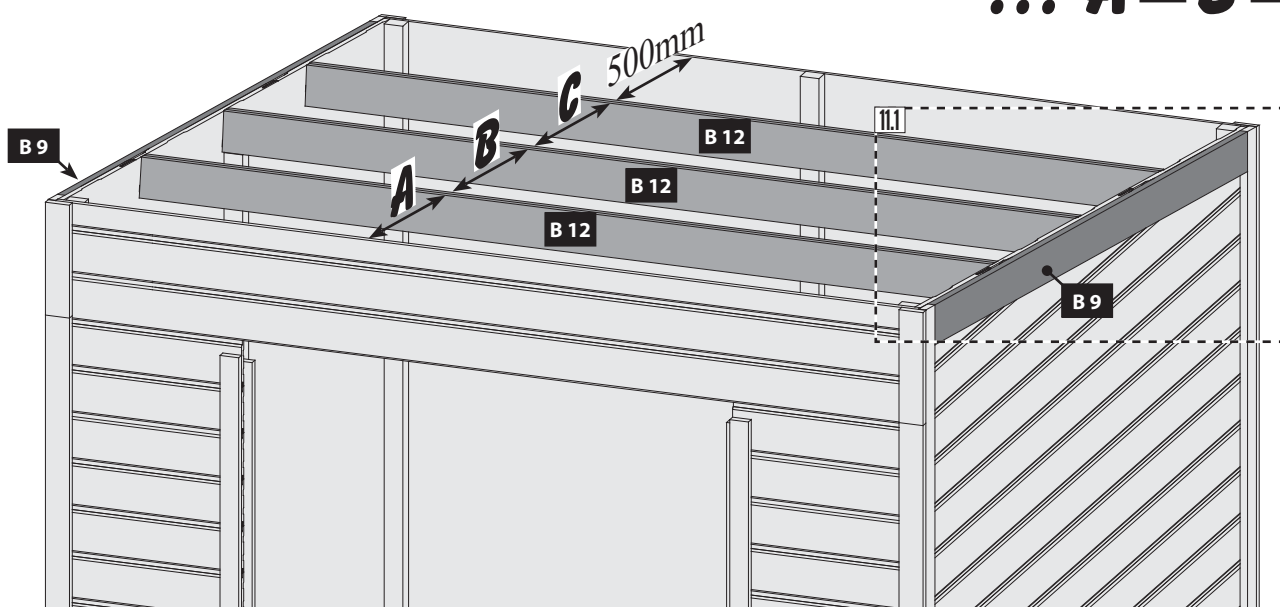

11.1-1

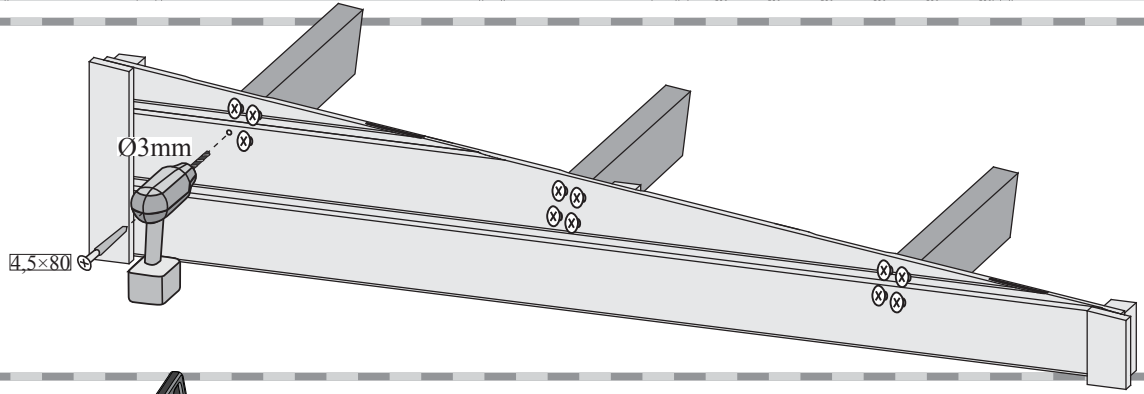
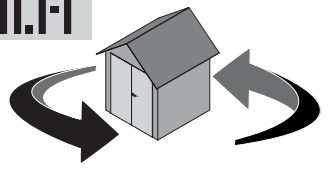

11.1-2

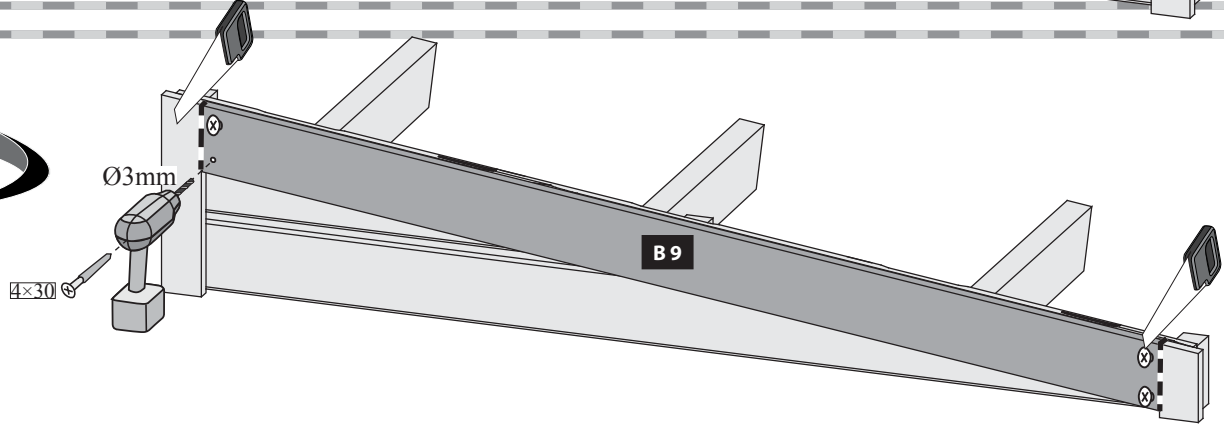
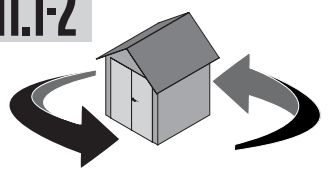

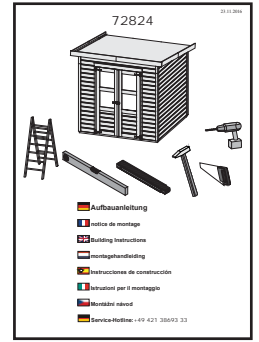
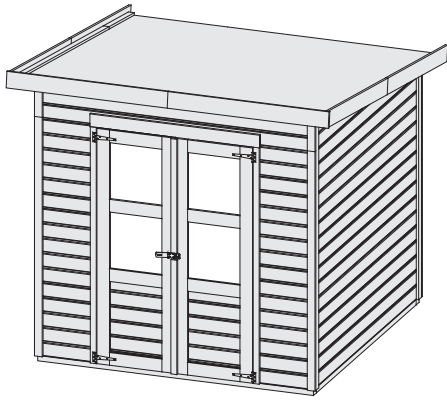

! 12 A + 13 + ...

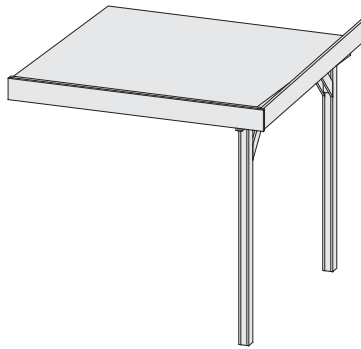
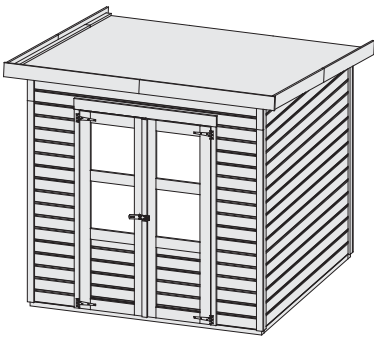

12 B !

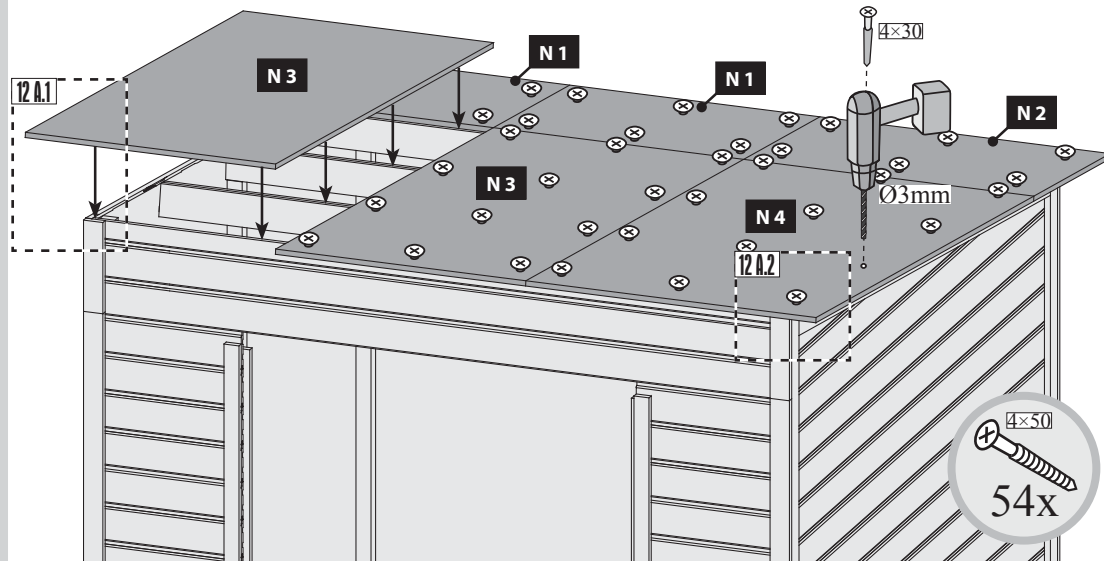
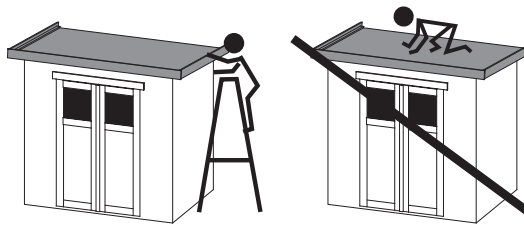
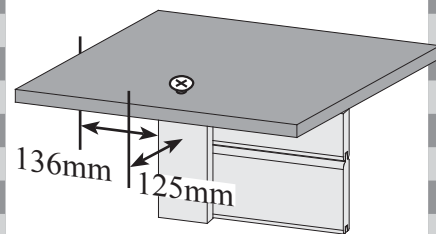
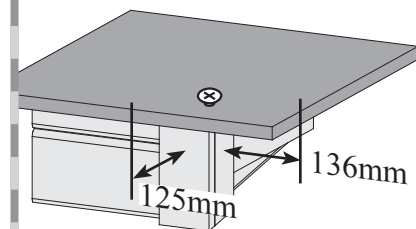
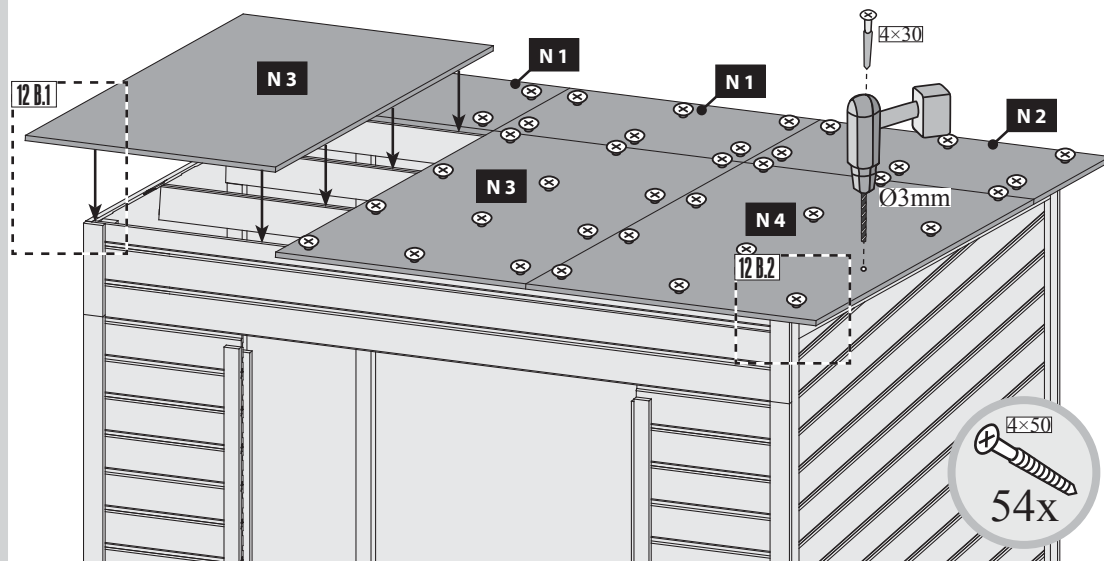
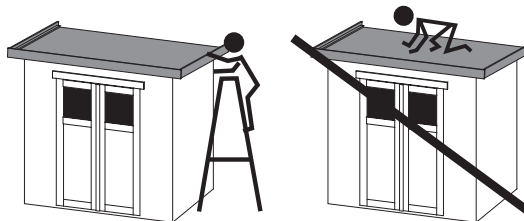
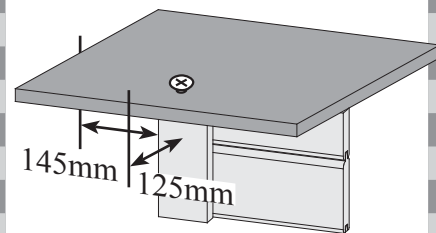
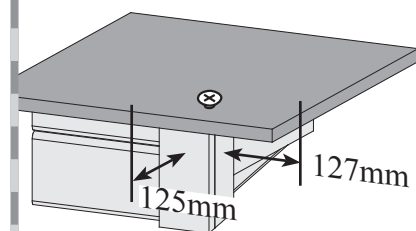

01 + 02 + ...

12 A**12 A.1****12 A.2****12 B****12 B.1****12 B.2**

Bei Anbaudach rechts: Dachüberstand

Haus links = 145mm/rechts = 127mm •

Bei Anbaudach links: Dachüberstand Haus

links = 127mm/rechts = 145mm

Lors du montage de droite sur le toit:

Débord de toit Maison gauche = 145 mm / droite

= 127mm • **Lorsque le toit de montage gau-**

che: Débord de toit Maison gauche = 127 mm /

droite = 145mm

At the right hand side: Roof overhang

house left = 145 mm / right = 127mm •

On the left: Roof overhang house left = 127 mm /

right = 145mm

Bij de montage van het dak rechts:

Dakoverstek House links = 145 mm / rechts =

127mm • **Bij de montage van het dak links:**

Dakoverstek House links = 127 mm / rechts =

145mm

Durante el montaje del techo derecho:

Casa alero izquierda = 145 mm / derecha =

127mm • **Quando el techo de montaje**

izquierdo: Casa alero izquierda = 127 mm /

derecha = 145mm

Durante il montaggio a destra del tetto:

Tetto sbalzo lasciato casa = 145 mm / destra

= 127 mm • **Quando il tetto di montaggio a**

sinistra: Tetto sbalzo lasciato casa = 127 mm /

destra = 145 mm

Při montáži střešní právo: Přesah

střechy domu vlevo = 145 mm / vpravo = 127

mm • **Při montáži střechy vlevo:** Přesah

střechy domu vlevo = 127 mm / vpravo = 145

mm

13 1x

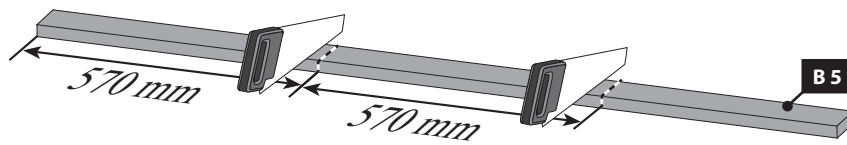



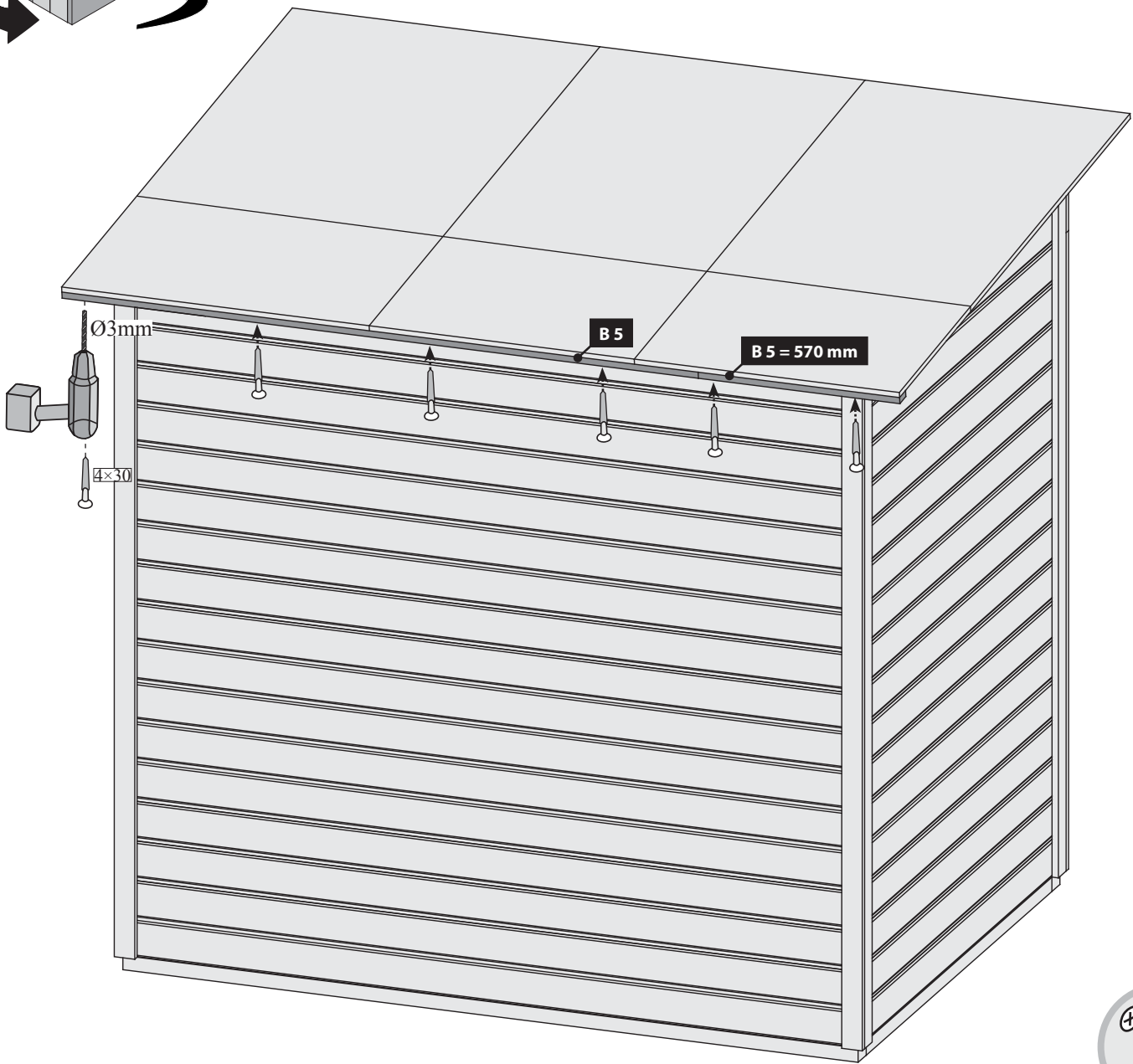
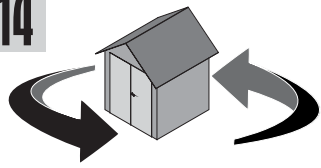



14



2x



ID 68589

-  Für die dauerhafte Eindeckung empfehlen wir die selbstklebende Bitumendachbahn aus unserem Sortiment
-  For permanent covering, we recommend self-adhesive bitumen roofing sheet from our range
-  Pour revêtement permanent, nous vous recommandons de bitume auto-adhésif tôle de toiture de notre gamme
-  Voor permanente bedekking, raden wij zelfklevende bitumen dakbaan uit ons assortiment
-  Para cobertura permanente, recomendamos betún autoadhesivas Perfil de cubierta de nuestra gama
-  Per copertura permanente, si consiglia di bitume autoadesive Lastra per coperture della nostra gamma
-  Pro trvalé krytinou, doporučujeme samolepicí asfaltové střešní krytiny z našeho sortimentu

 Montage Bitumendachbelag

 Montage Couverture en carton bitumé

 Roofing felt installation

 Montage dakvilt

 Montaje de tela asfáltica

 Montaggio del cartone catramato

 montáž střešní krytiny

 **Achtung, dies ist nur ein Verlegebeispiel!**

Der mitgelieferte Bitumendachbelag dient zur Ersteindeckung und sollte nach 2 Monaten durch ein eigenes Produkt ergänzt werden.

Die Anzahl der Bahnen richtet sich nach Ihrer Hausgröße. Stöße während einer Bahn sind mit einem Überschlag von ca 10cm durchzuführen. Bei Verwendung von nur 4 Bahnen keine Firstbahn verwenden, seitliche Bahnen mit über den First legen. Das Dach ist nicht begehbar. Die Konstruktion ist für eine Gesamtbelastung (Schnee, Wind) und nicht für eine Punktbelastung ausgelegt. Zur Montage empfehlen wir eine bauseitige Abstützung des Daches von unten. Die Abdichtung der Dachflächen zu den Windbrettern an den Stirnseiten ist bauseits zu lösen!

Bei einem Satteldach-Haus sollten Sie bei der Verwendung von Schindeln keine Voreindeckung vornehmen. Hier wird nur an beiden Traufseiten ein 20cm breiter Streifen Dachpappe mit Überstand verlegt. Bei Häusern mit einem Tonnendach verlegen Sie bitte einen Bitumendachbelag unter die Schindeln. Bei einem Flachdach ist die Verlegung von Dachschindeln nicht möglich!

 **Attention, il s'agit uniquement d'un exemple de pose!**

Le nombre de bandes de carton bitumé dépend de la taille de la maison. La jointure du carton bitumé sur une bande doit être réalisée avec une superposition de 10 cm. Si 4 bandes seulement sont utilisées, ne pas avoir recours à une bande de faite, appliquer les bandes latérales sur le faite.

Ne pas marcher sur le toit ! La construction peut supporter une charge répartie sur sa totalité (neige, vent), et non concentrée sur un point précis. Lors du montage, il vous est recommandé d'étayer le toit par en dessous.

Si votre maison possède un toit en bâtière, ne pas poser de couverture préalable en carton bitumé pour les couvertures en bardeaux. Pour les maisons avec toit en berceau, poser du carton bitumé sous les bardeaux. Pour profiter le plus longtemps possible de votre maison de jardin, renouveler la couverture du toit tous les deux meses. Pour les maisons de toit plat de la pose de bardeaux de toiture est pas possible!

 **Note! This description is only an example!**

The number of required rolls of roofing felt depends on the actual size of the summer house. When joining rolls of roofing felt end to end, the overlap must be 10 cm. When using just 4 rolls of roofing felt, always cover the horizontal ridge beam with the rolls from both sides.

The roof is not safe to walk on. The roof is designed for a total load (snow, wind) and not for a point load. We recommend you to always support the roof from below during installation.

When using shingles to cover a house with a gable roof, never use roofing felt as a preliminary covering. Always install the roofing felt underneath the shingles for houses with an arched roof. To ensure maximum enjoyment of your summer house, renew the roof covering after two month. For flat roof houses the laying of roofing shingles is not possible!

 **Let op, dit is slechts een montagevoorbeeld!**

Het aantal dakviltbanen is afhankelijk van de grootte van uw huis. Voegen van dakvilt tijdens een baan dienen met een overlapping van 10cm uitgevoerd te worden. Bij gebruik van slechts vier banen geen firstbaan gebruiken, banen aan de zijkant ook over de first leggen.

Het dak is niet beloopbaar. De constructie is ontworpen voor een totaalbelasting (sneeuw, wind) en niet voor een puntbelasting. Voor de montage adviseren we te voorzien in een zelf aan te brengen steun voor het dak van onderen.

Wanneer u een huis met zadeldak hebt, zou u bij het gebruik van dakshingles geen voorafdekking met dakvilt moeten aanbrengen. Bij huizen met een boogdek dient u dakvilt onder de shingles aan te brengen. Om lang plezier van uw tuinhuisje te hebben, zou u deze dakafdekking na twee manden vervangen. Voor plat dak huizen de aanleg van de dakbedekking shingles is niet mogelijk!

 **Cuidado, éste es sólo un ejemplo de instalación!**

La cantidad de tiras de tela asfáltica depende del tamaño de su caseta. Las juntas de tela en una tira se realizan solapando la tela asfáltica 10 cm. Cuando sólo se empleen cuatro tiras no se debe utilizar ninguna tira de cumbrera, sino colocar las tiras laterales sobre la cumbrera.

El techo no es transitable. La construcción está preparada para cargas totales (nieve, viento) y no para cargas puntuales. Para el montaje se recomienda apuntalar el techo por debajo.

Si tiene una casa con tejado a dos aguas, en caso de utilizar cubierta de ripias no se debería cubrir previamente con tela asfáltica. En las casas con tejado en forma de tonel, por favor coloque la tela asfáltica debajo de la cubierta de ripias. Para disfrutar de su caseta de jardín durante mucho tiempo se aconseja renovar la cubierta del tejado cada 2 meses. Para las casas de techo plano de la colocación de tejas para techos no es posible!

 **Attenzione, questo è solo un esempio di posa!**

La quantità dei rulli di cartone catramato dipende dalle dimensioni della casa. Le congiunzioni del cartone catramato in una corsia vanno con una sovrapposizione di 10 cm dei due pezzi di cartone catramato. Se si impiegano 4 file non dispone una sul colma ma far passare un bordo oltre il colmo stesso.

Non salire sul tetto. La costruzione è progettata per un carico diffuso (neve, vento) e non per una concentrazione puntuale del peso. Per il montaggio si consiglia un supporto del tetto con una costruzione posta sotto di esso.

Se si utilizza la scandola per rivestire il tetto, non si dovrebbe utilizzare il rivestimento in cartone catramato. Per case con tetto a botte, posare il cartone catramato sotto la scandola. Per garantire una lunga durata della casetta da giardino, è necessario rinnovare la copertura del tetto ogni 2 mesi. Per le case tetto piano la posa di tegole di copertura non è possibile!

 **Pozor, toto je jen příklad, kterým!**

Počet Dachpappbahnen závisí na velikosti domu. Hromady střešní lepenky při vln musí být provedeno s převrácení 10 cm střešní lepenky. Při použití pouze čtyři běhy ne Firstbahn použití, boční panely s ležel přes hřeben.

Střecha není přístupný. Konstrukce je (sníh, vítr) a není určen pro bodové zatížení na celkové zatížení. Pro montáž doporučujeme znovu podporu na místě střechy zespodu. Utěsnění střešních oblastí do pohledu na čelních plochách je na místě řešit!

Pokud máte dům se sedlovou střechou, měli byste při používání šindele žádný Voreindeckung s střešní lepenky. Zde je 20 cm široký pás střešní plst' je pouze na obou stranách okapového se supernatantem odloženou (obrázek 02.2 níže). Pro rodinné domy s valenou střechou prosím ležel lepenkový pod šindelem. Chcete-li prodloužit požitek z vašeho zahradního domku, měli byste obnovit tuto střešní krytinu po 2 měsících. Pro ploché střechy domů pokládka střešních šindelů není možné!

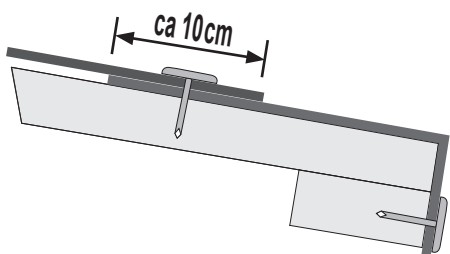

*

 Nicht im Lieferumfang enthalten

 Niet bijgeleverd

 Not included

 Non comprises dans la livraison

 No forman parte del suministro

 Non incluso

 V ceně není zahrnuto

 Vor Feuchtigkeit schützen!

 Beschermen tegen vocht!

 Protect from moisture!

 Protéger de l'humidité!

 Protegerlo de la humedad!

 Proteggere dall'umidità!

 Chránit před vlhkostí!

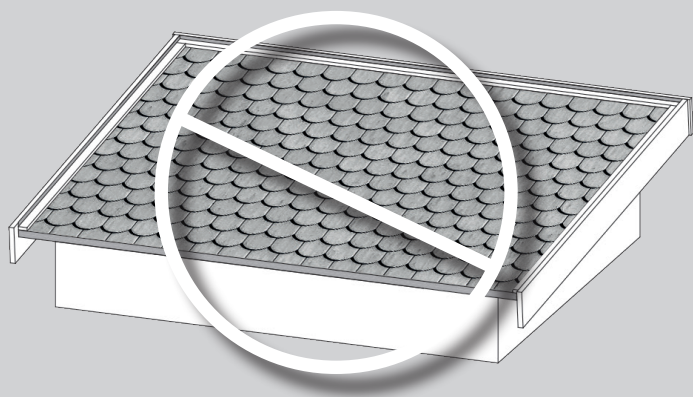
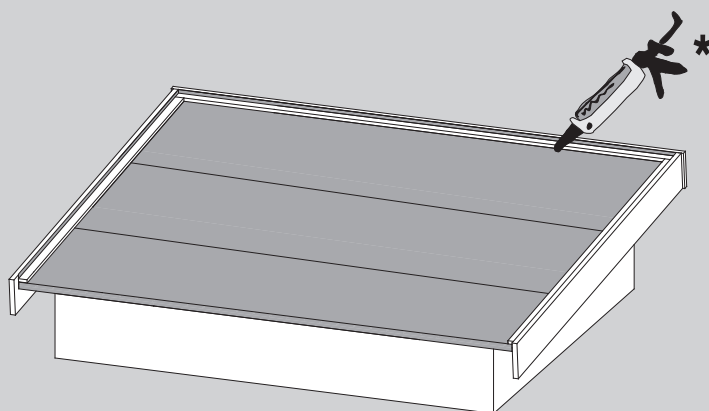
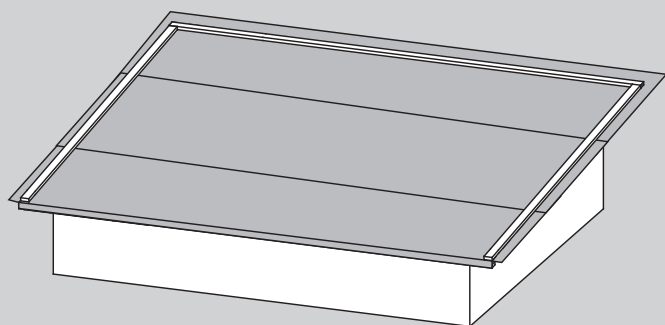
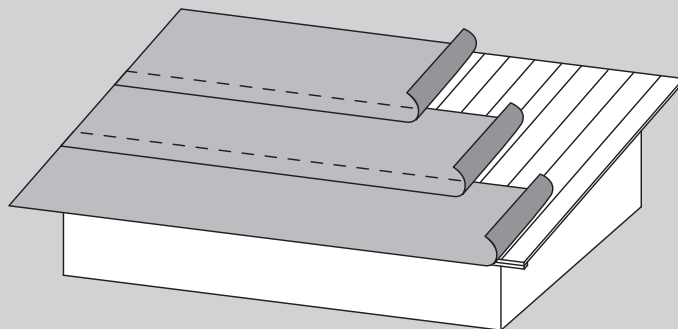
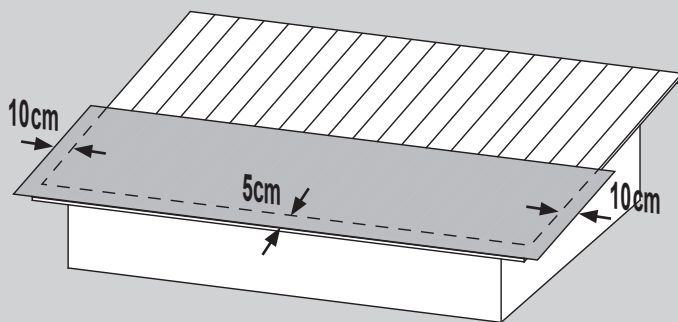

15

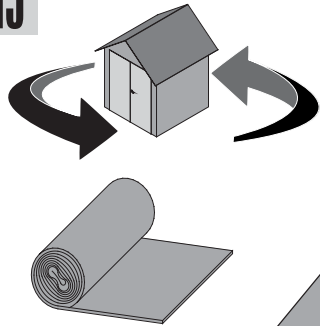

- Kleber
- Colle
- Glue
- Lijm
- Pegamento
- Colla
- Lepek

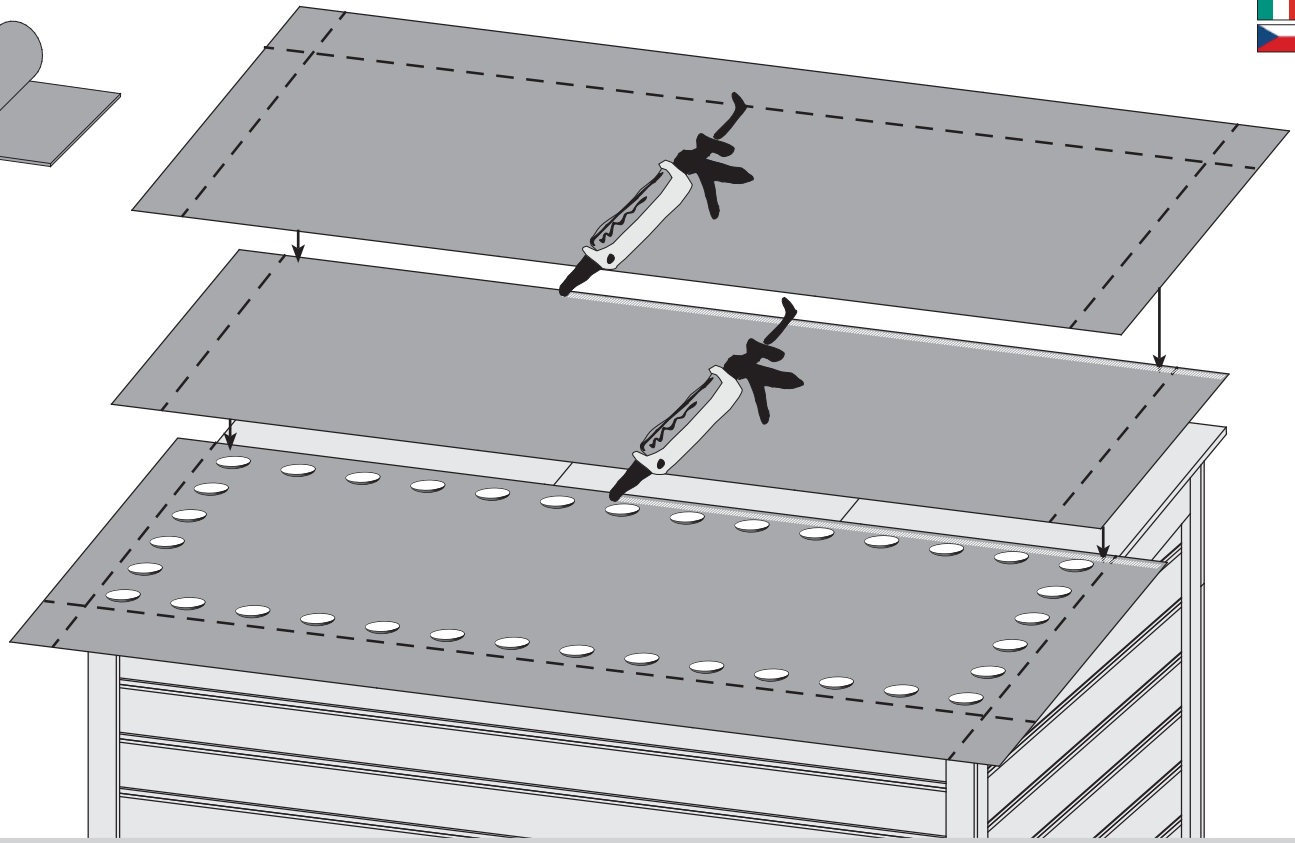

16

1x

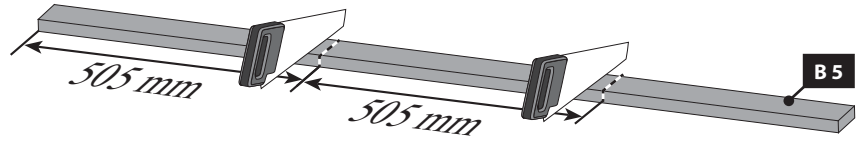

17

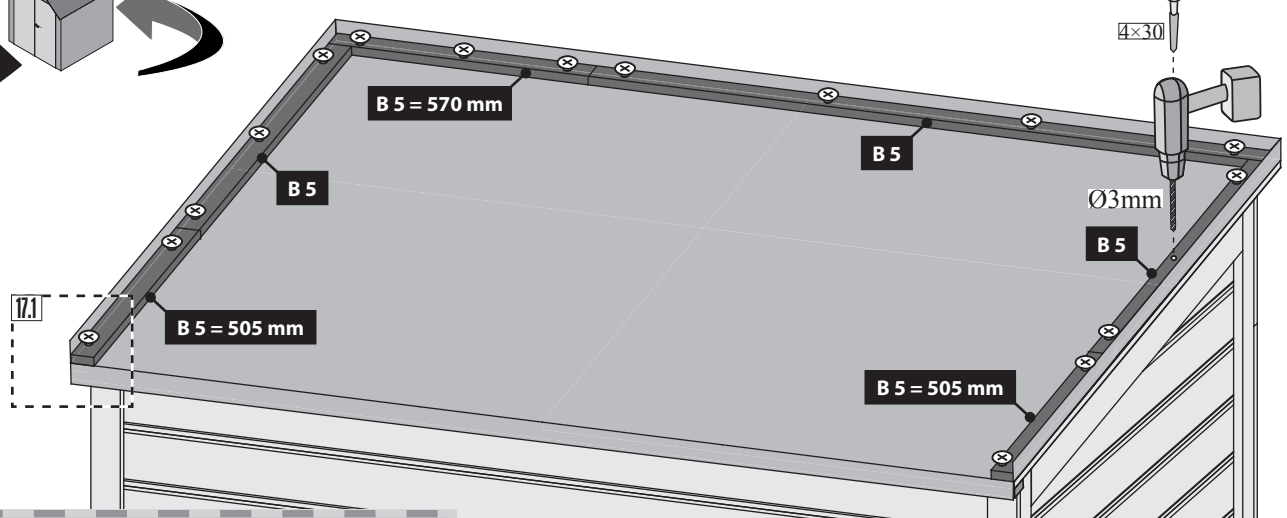
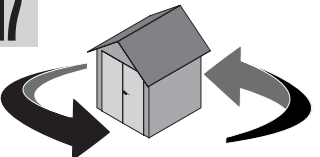

17.1

- Bündig!
- Affleurement!
- Gelijk!
- Aras!
- Flush!
- Combacia!
- Flush!

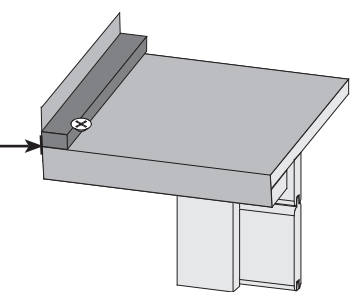

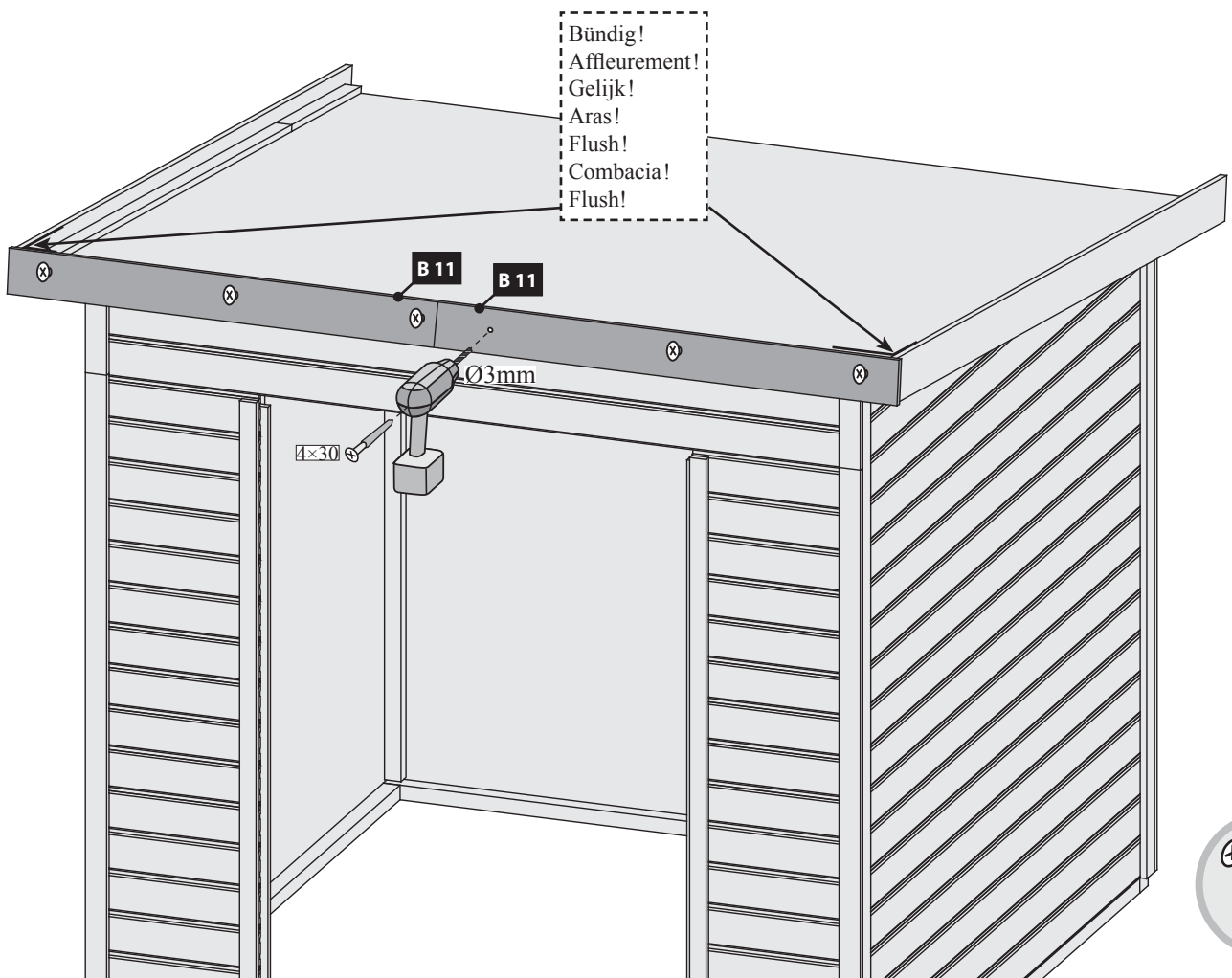
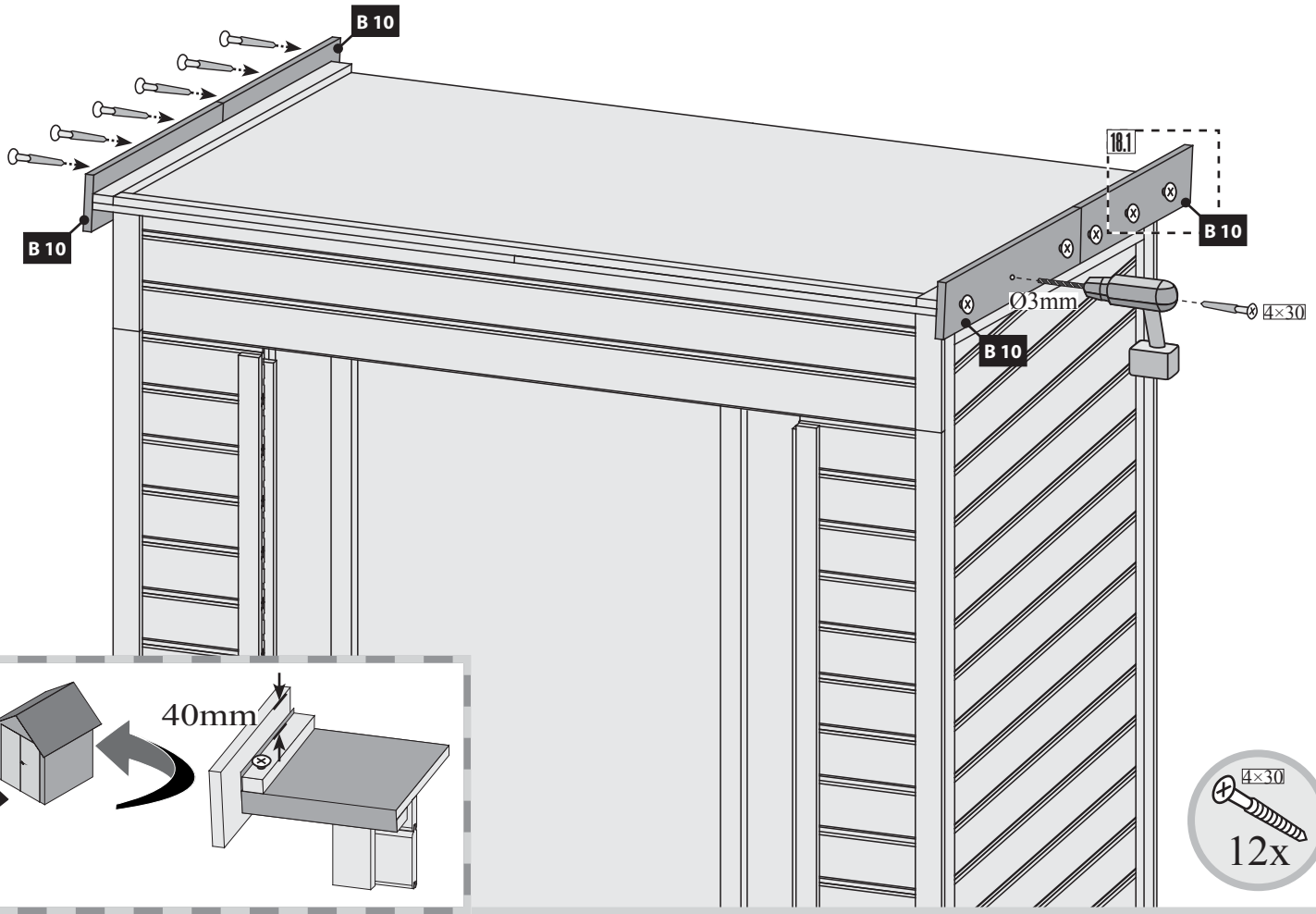

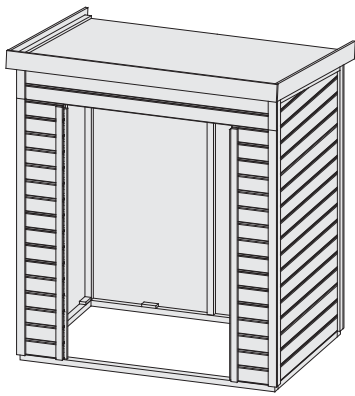

20 A + 21 A

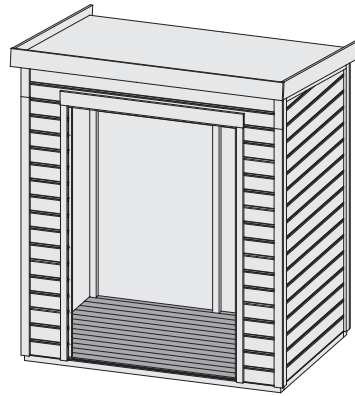

20 B + 21 B

20 A

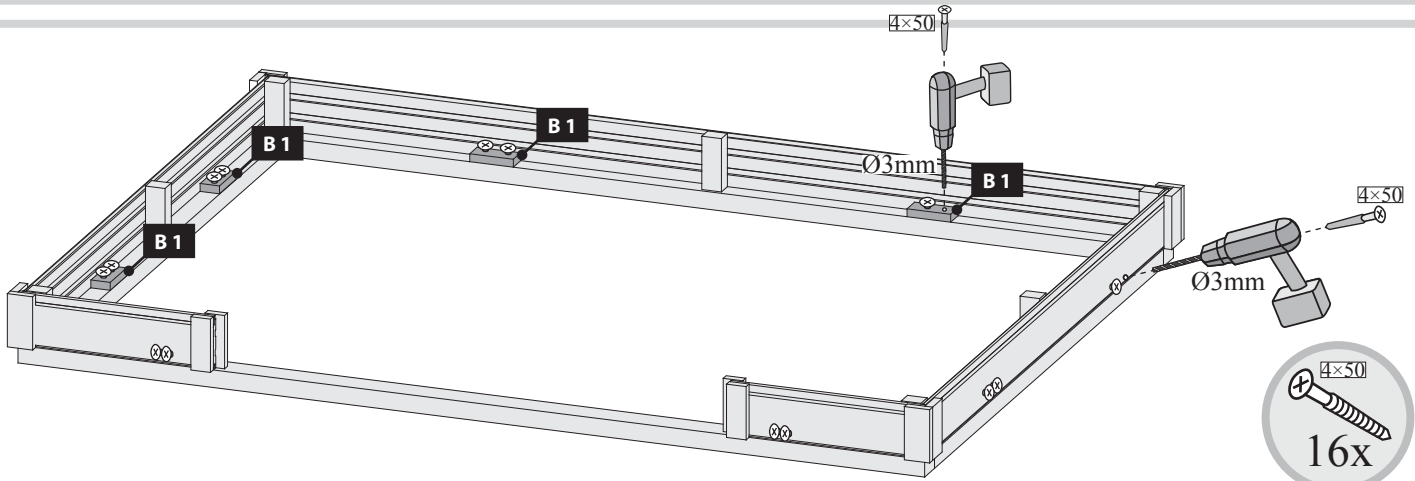

21 A

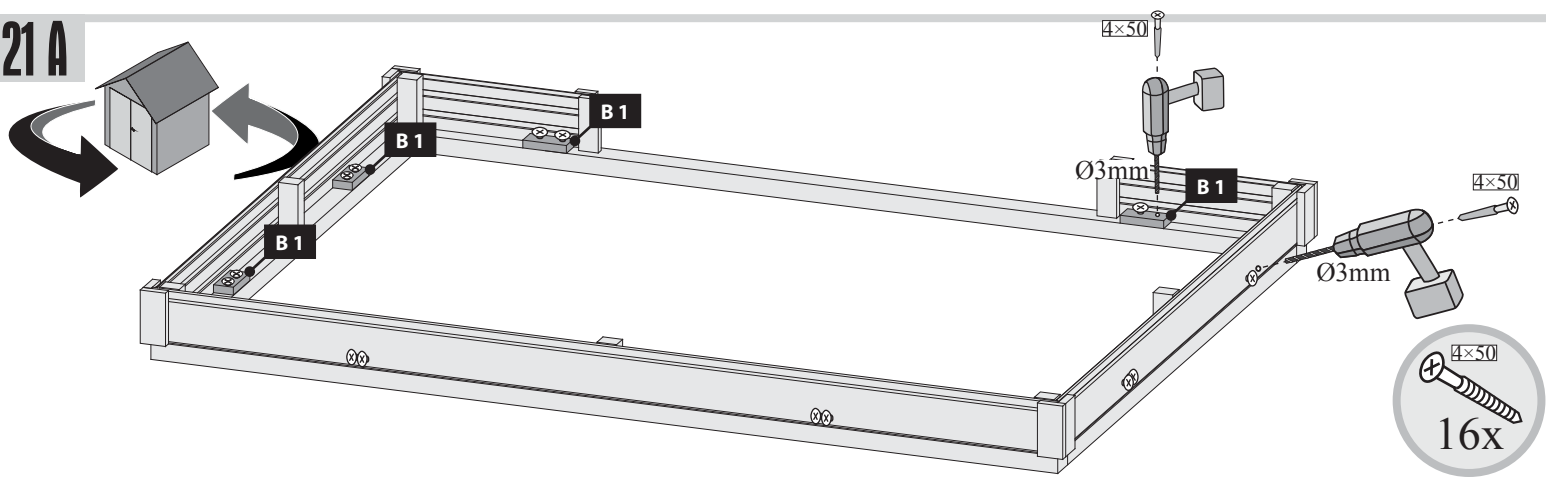

20 B

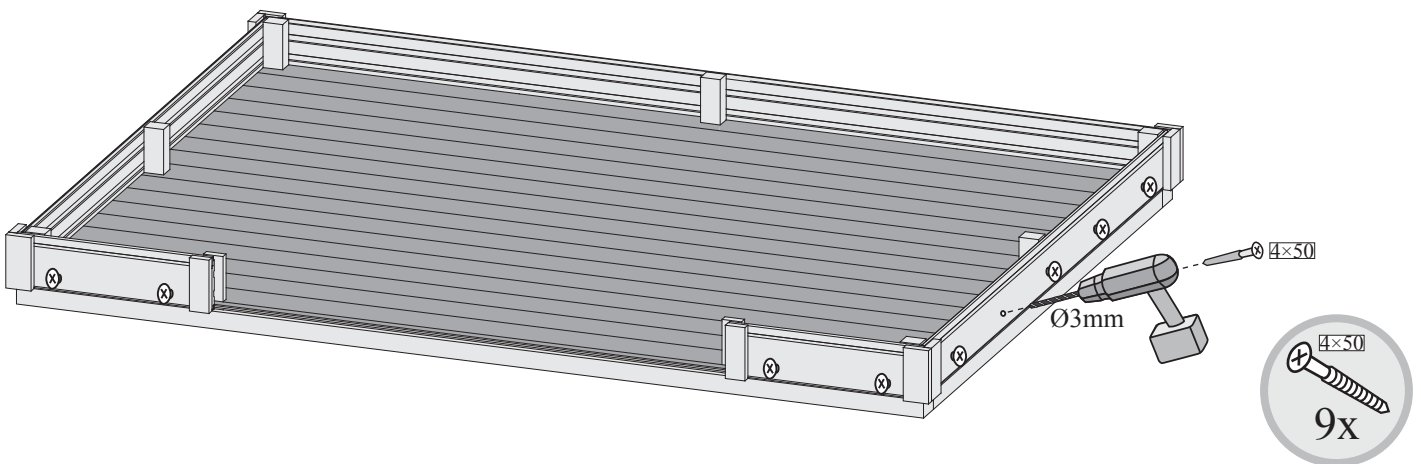

21 B

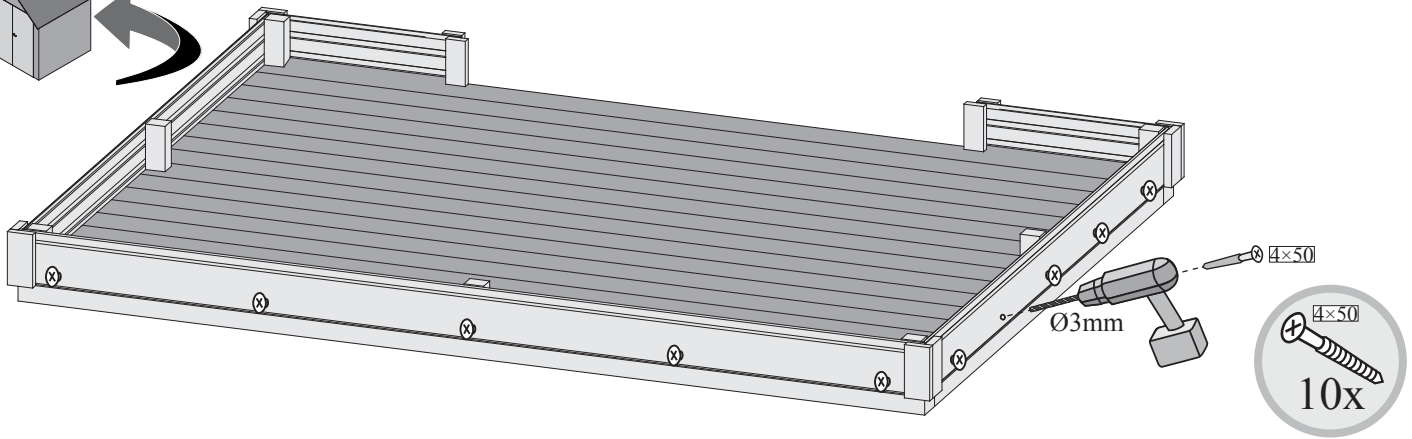
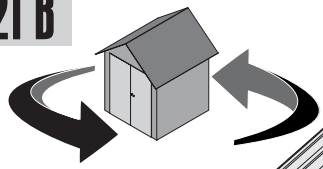

22

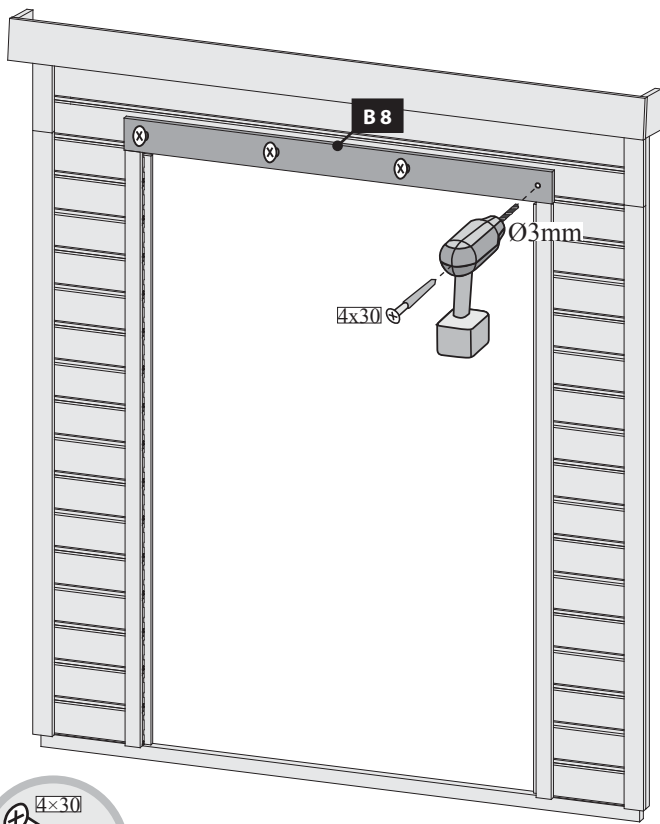

23

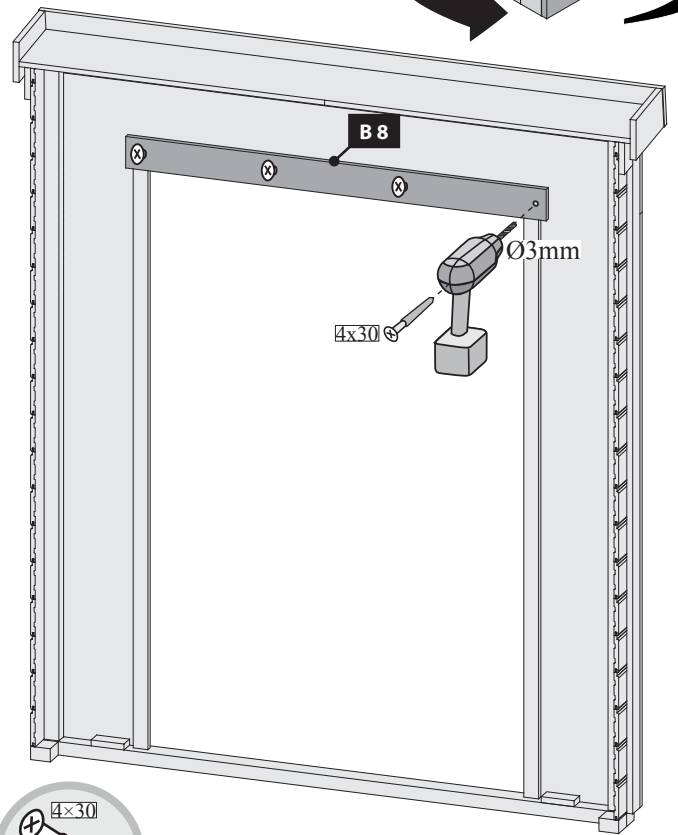
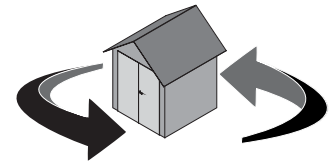

24 1x

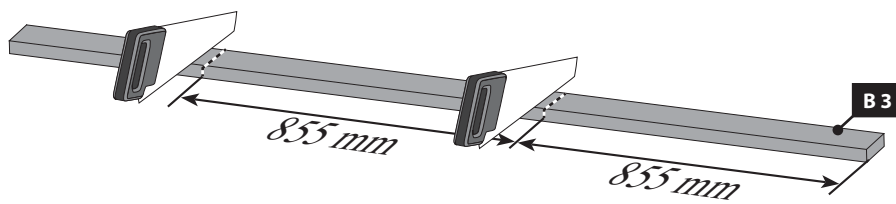

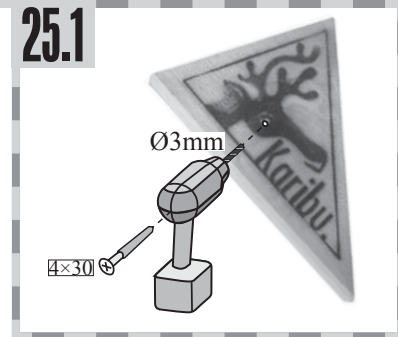
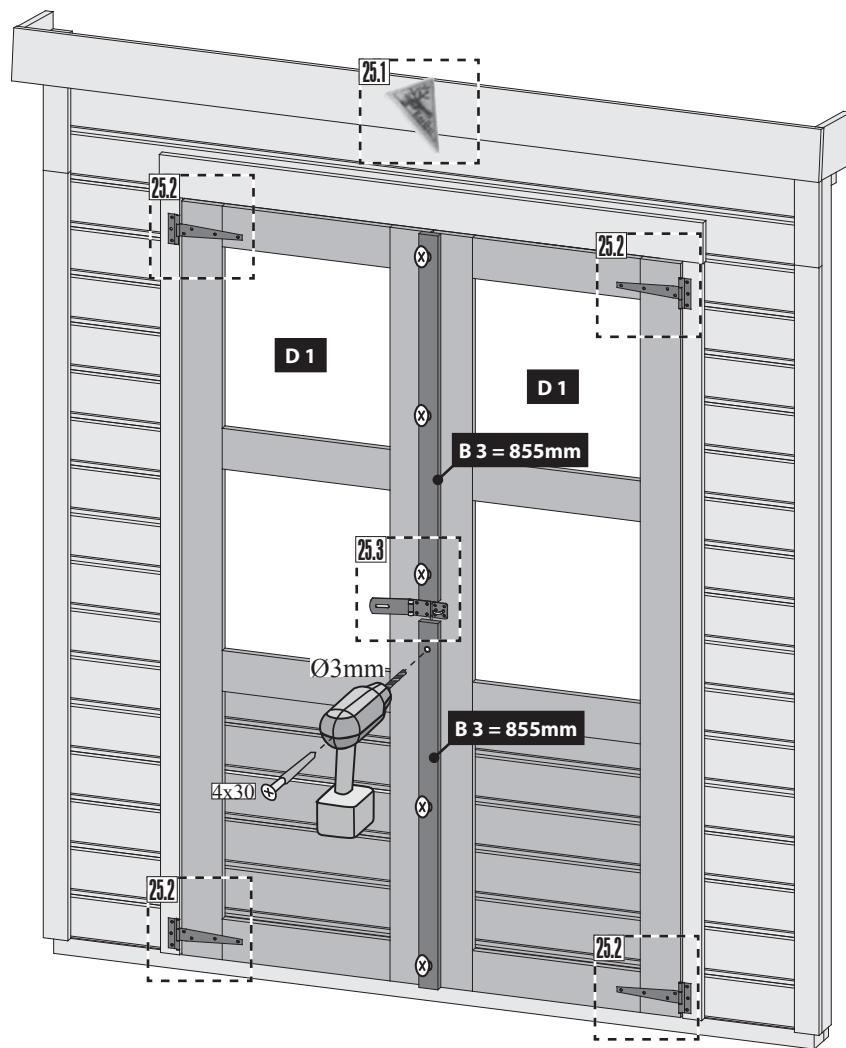

25.2

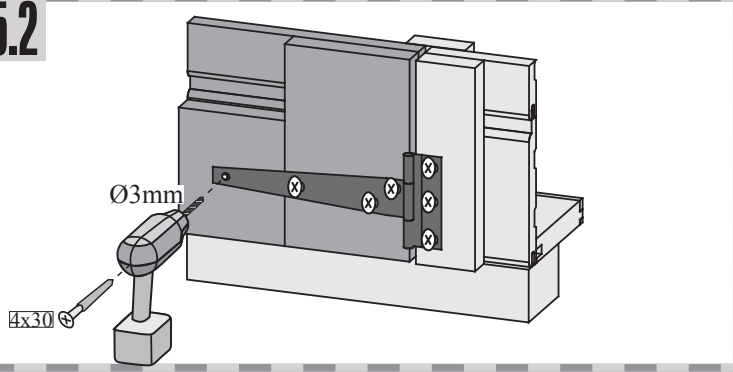

25.3-2

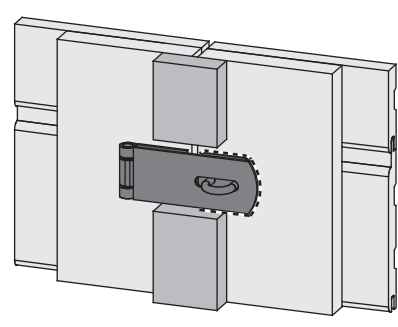

25.3-1

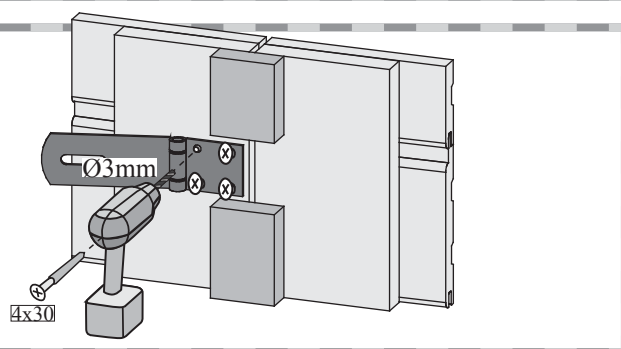

25.3-3

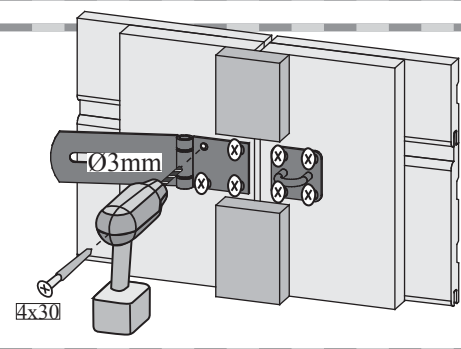

26

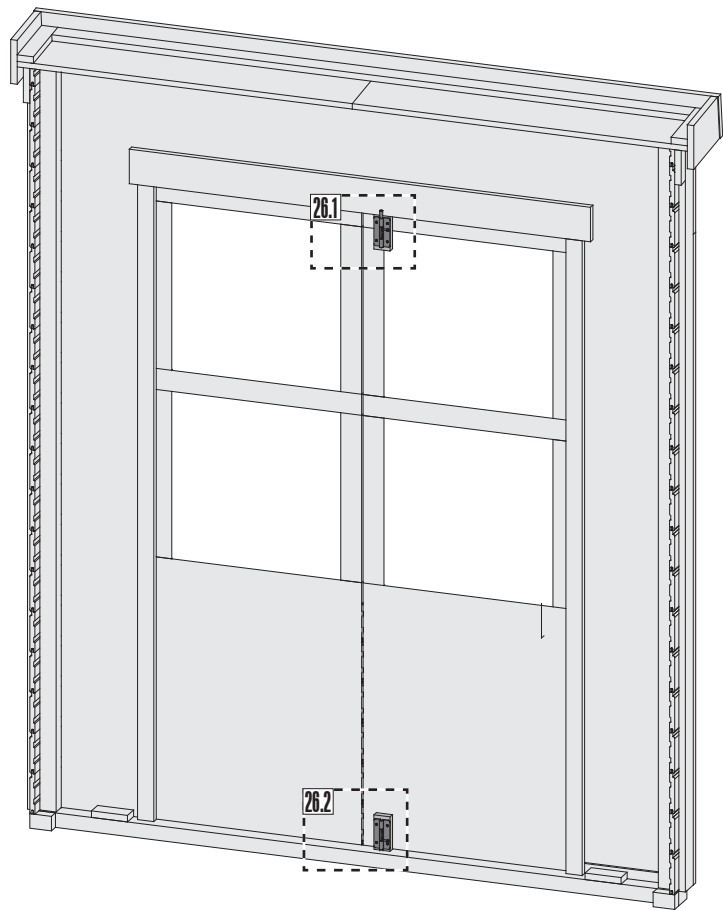
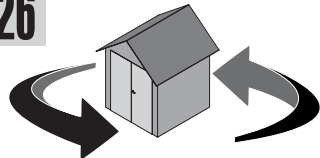

26.1-1

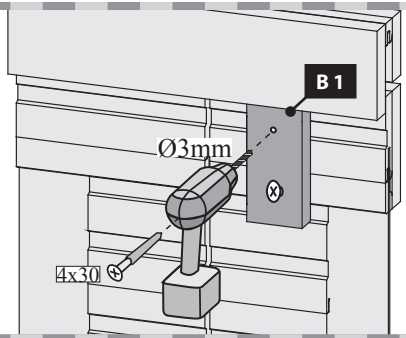

26.2-2

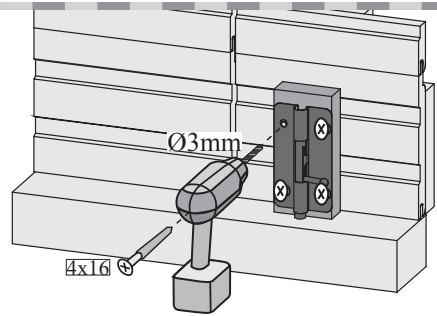

26.1-2

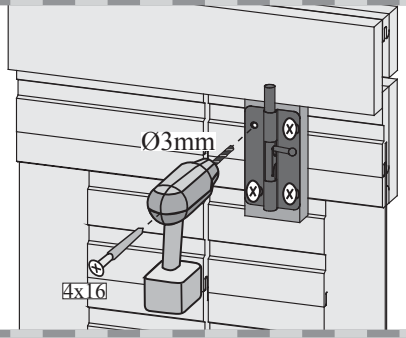

26.2-3

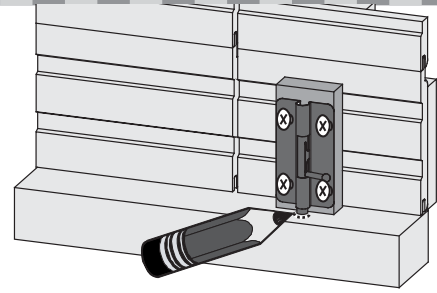

26.2-1

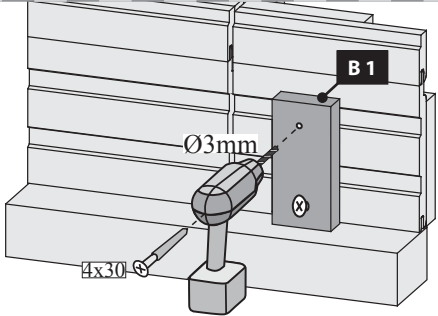

26.2-4

